

# YFD41X BUTTERFLY VALVE

## Product Description

YFD41X double flange butterfly valve is designed for stable installation, reliable sealing, and long-term durability in demanding pipeline systems.

With an integral double flange body structure, the valve can be directly bolted to pipeline flanges, ensuring excellent alignment, high structural strength, and superior sealing performance under high pressure and large diameter conditions.

Equipped with a high-performance resilient seat, precision-machined disc, and corrosion-resistant epoxycoating, this valve is widely used in water treatment, municipal infrastructure, power plants, and general industrial applications.



### Technical Data

Size range	DN50-DN2400
Pressure range	PN 10-16/Class 150/JIS10K
Temperature	EPDM : -10°C to +100 °C NBR: - 10°C to + 80 °C VITON :-10°C to + 180°C
Design	API609
Face to face	API609
Connection	EN 1092-1 PN16
Coating	Electrostatic Powder Epoxy/Spray
Testing	API598
Medium	Water,oil,Gas

### Application Range

- HVAC Systems
- Pumping Stations
- Water Treatment Plants
- Reservoirs and Tanks
- Irrigation
- Industrial Applications

### Related Products

- YFZ44T MATEL SEAT GATE VALVE
- YFPZ73X KNIFE GATE VALVE
- YFH44X SWING CHECK VALVE



HVAC



IRRIGATION



POTABLEWATER



INDUSTRY

# YFD41X BUTTERFLY VALVE

## Product Description

---

### 1. Compact Design with Low Torque Operation

The compact structure enables quick 90° operation, while optimized disc and sealing design ensure low torque and smooth performance.

### 2. High-Performance Vulcanized Rubber Seat

The seat contains over 50% natural rubber and is fully vulcanized to the valve body, ensuring excellent elasticity, strong bonding, and a service life exceeding 30,000 cycles.

### 3. Reliable Sealing System

Dual sealing design with O-rings and oil seals ensures leak-free performance. For large sizes (DN350+), a stuffing box structure provides enhanced sealing reliability.

### 4. Durable Epoxy Coating for Corrosion Protection

High-quality epoxy powder coating offers strong adhesion, excellent corrosion resistance, and long-term durability for indoor and outdoor use.

### 5. Double Flange Structure for Secure Installation

The integral double flange design ensures accurate alignment, stable installation, and suitability for large diameter and high-pressure applications.



# YFD41X

## BUTTERFLY VALVE

Worm Gear DN50-DN350

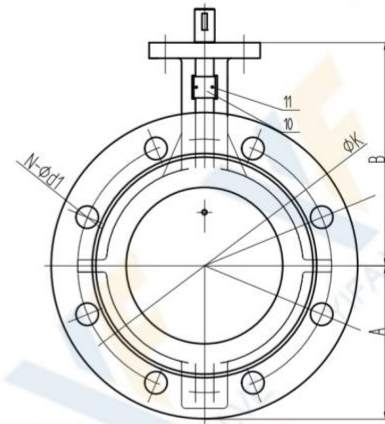

No.	Name	Qty.	Materials
1	Body	1	DI/WCB/SS304
2	Bushing	1	Combined polymer
3	Seat	1	EPDM/NBR/VITON
4	Disc	1	DI/CF8/CF8M
5	Stem	1	SS410
6	Bushing	3	Combined polymer
7	O ring	1	EPDM
8	U collar	1	SS201/SS304
9	Clamp spring	1	Spring steel
10	Hexagon bolt	1	SS201/SS304
11	Wormgear	1	Cast Iron Aluminum

### Inspection specification

PN	16
Seal test	1.76 MPa
Shell test	2.4 MPa
Suitable medium	Water,Oil,Gas

SIZE		A	B	C	L	ANSI 150B		PN 10		PN 16		JIS 10K	
mm	in					øK	N-ød	ØK	N-ød	ØK	N-ød	øK	N-ød
50	2"	78	123	32	108	120.6	4-φ19	125	4-Ø18	125	4-φ18	120	4-φ19
65	2½"	72	136	32	112	139.7	4-φ19	145	4-φ18	145	4-φ18	140	4-φ19
80	3"	88	146	32	114	152.4	4-φ19	160	8-φ18	160	8-φ18	150	8-φ19
100	4"	96.5	158	32	127	190.5	8-φ19	180	8-φ18	180	8-φ18	175	8-φ19
125	5"	115	179	32	140	215.9	8-φ22.4	210	8-φ18	210	8-φ18	210	8-φ23
150	6"	126	197	32	140	241.3	8-φ22.4	240	8-φ22	240	8-φ22	240	8-φ23
200	8"	161	230	45	152	298.4	8-φ22.4	295	8-φ22	295	12-22	290	12φ23
250	10"	199	271	45	165	361.9	12-ø25.4	350	12-φ22	355	12-26	355	12-φ25
300	12"	215	305	45	178	431.8	12-25.4	400	12-φ22	410	12-26	400	16-φ25
350	14"	261	350	45	190	476.2	12-28.4	460	16-ø22	470	16-26	445	16-ø25

# YFD41X

## BUTTERFLY VALVE

Worm Gear DN400-DN1200

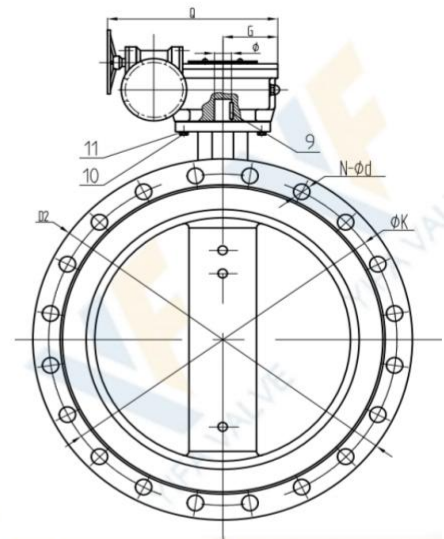

### Inspection specification

PN	16
Seal test	1.76 MPa
Shell test	2.4 MPa
Suitable medium	Water, Oil, Gas

No.	Name	Qty.	Materials
1	Body	1	DI
2	Bushing	1	Combined polymer
3	Seat	1	EPDM/NBR/VITON
4	Disc	1	DI/CF8/CF8M
5	Stem	1	SS410
6	Clamp spring	1	Spring steel
6	Bushing	3	Combined polymer
7	O ring	1	NBR
8	U collar	1	SS201/SS304
10	Wormgear	1	Cast iron Aluminum

SIZE		A	B	C	L	ANSI 150B		PN 10		PN 16		JIS 10K		TOP FLANGE
mm	in					ØK	N-ød	ØK	N-ød	ØK	N-ød	ØK	N-ød	
400	16"	290	381	51	216	539.7	16-φ28.4	515	16-φ26	525	16-Ø30	510	16-φ27	F14
450	18"	307	392	51	222	577.8	16-φ31.8	565	20-φ26	585	20-φ30	565	20-φ27	F14
500	20"	340	441	57	229	635.0	20-φ31.8	620	20-φ26	650	20-φ33	620	20-φ27	F14
600	24"	396.0	500	70	267	749.3	20-φ35.1	725	20-φ30	770	20-φ36	730	24-φ33	F16
700	28"	496	567	66	292	863.6	28-φ35.1	840	24-φ30	840	24-φ36	840	24-φ33	F25
800	32"	543	641	66	318	978	28-Ø41.1	950	24-φ33	950	24-φ39	950	28-φ33	F25
900	36"	584	692	118	330	1085.8	32-Ø41.1	1050	28-φ33	1050	28-φ39	1050	28-φ33	F25
1000	40"	638	735	142	410	1200.2	38-φ41.1	1160	28-φ36	1170	28-42	1270	28-φ39	F25
1200	48"	763	917	150	470	1422.4	44-Ø41.1	1380	32-φ39	1390	32-φ48	1380	32-φ39	F25

# YFD41X

## BUTTERFLY VALVE



### Torque

Size	Pn6		PN10		Pn16	
	ΔP=100		ΔP=150		ΔP=200	
	WET	DRY	WET	DRY	WET	DRY
DN50	13	20.8	13.9	22.1	15.1	24.2
DN65	13.8	26.1	15.4	29.2	17.2	32.7
DN80	21	39.9	21.7	41.1	23.1	43.7
DN100	34.9	63.8	37.1	67.8	39.8	72.8
DN125	53.8	93.8	57.9	101	61.9	108
DN150	84.5	149	93.9	165	102	174
DN200	154	264	173	297	192	330
DN250	249	423	286	486	323	549
DN300	371	605	429	699	490	799
DN350	466	699	550	825	625	969
DN400	632	947	755	1133	846	1307
DN450	831	1246	1012	1518	1131	1787
DN500	1093	1639	1350	2025	1431	2288
DN600	1679	2519	2111	3166	2301	3711
DN700	3010	4515	3272	4908	4253	6380
DN750	3487	5231	3767	5650	4897	7345
DN800	3963	6103	4308	6462	5600	8400
DN900	4913	7369	5257	7886	6834	10251
DN1000	8367	12550	8926	13389	11603	17405
DN1050	8433	12649	9024	13536	11731	17596
DN1200	11733	17600	12555	18833	16321	24482

Note:

- 1、The above "WET" means the test fluid is water or other non-lubricating mediums." DRY" means the test medium is dry compressed air.
- 2、When the valve serves in a too low working temperature, operating torque will increase with the consequence of increased hardness of rubber in low temperature.

# YFD41X

## BUTTERFLY VALVE



### Pressure drops

DN	Kv	Cv
50	167	160
65	290	275
80	380	365
100	650	620
125	1165	1115
150	1520	1450
200	2835	2710
250	4485	4285
300	5675	5420
350	7130	6810
400	9220	8805
450	11465	10950
500	14940	14270
600	21875	20895

$$Kv = Q \sqrt{\frac{d'}{\Delta P}}$$

$$\Delta P = \left( \frac{Q}{Kv} \right)^2 d$$

Kv: flow coefficient. Flow of water in m<sup>3</sup>/h passing through the valve and generating a pressure drop of 1 bar.

Q: flow in m<sup>3</sup>/h

Δ P: pressure drop in bar

d: relative density of the fluid (1 in the case of water at 4°C)

$$Cv = Q \sqrt{\frac{d}{\Delta P}}$$

$$\Delta P = \left( \frac{Q}{Cv} \right)^2 d$$

Cv: gallons per minute that pass through the valve for the pressure drop to be 1 psi.

Q: flow in gallons/min

Δ P: pressure drop in psi

d: relative density of the fluid (1 in the case of water at 60°F)

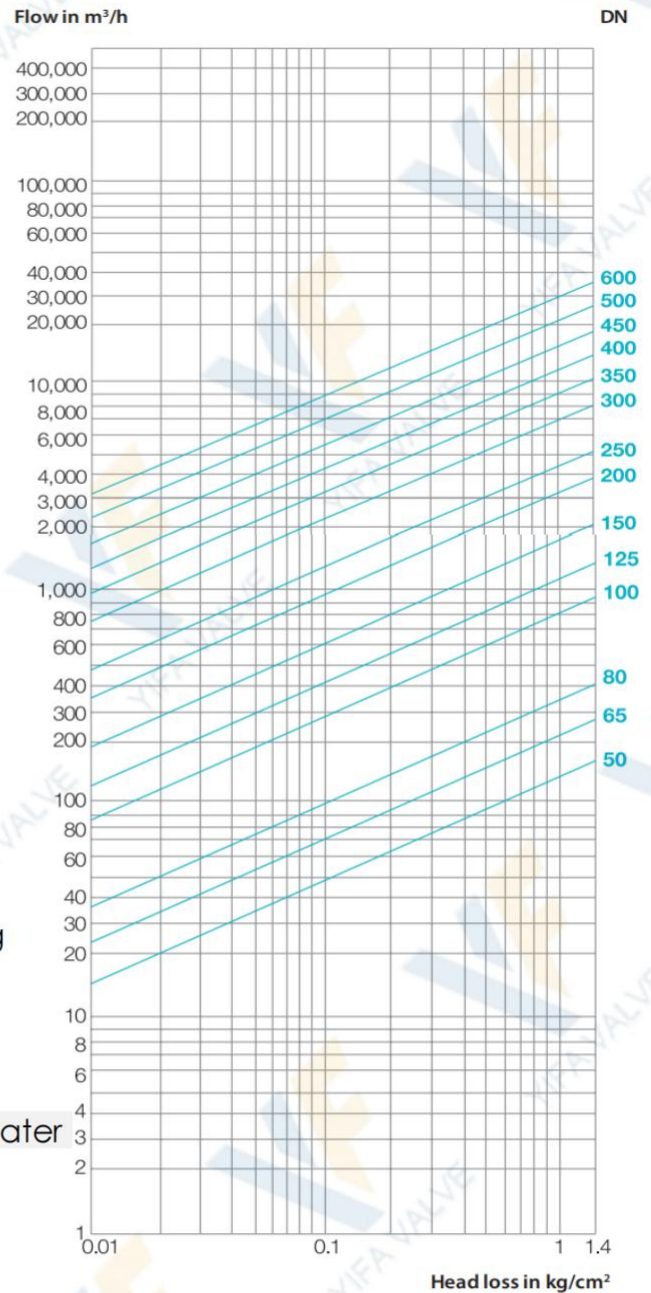

# YFD41X

## BUTTERFLY VALVE



### Cv Value

Concentric Butterfly Valve Flow Coefficient Cv Value (in<sup>2</sup>)

SIZE		Valve opening angle								
DN	NPS	10°	20°	30°	40°	50°	60°	70°	80°	90°
50	2	0.06	3	7	15	27	44	70	105	115
65	2½	0.1	6	12	25	45	75	119	178	196
80	3	0.2	9	18	39	70	116	183	275	302
100	4	0.3	17	36	78	139	230	364	546	600
125	5	0.5	29	61	133	237	392	620	930	1022
150	6	0.8	34	95	153	257	422	706	1154	1579
200	8	2	56	154	251	422	693	1158	1892	2165
250	10	3	87	238	385	654	1073	1794	2931	3353
300	12	4	153	417	681	1145	1879	3142	5132	5827
350	14	6	183	500	816	1372	2252	3765	6150	7037
400	16	8	271	740	1208	2031	3333	5573	9104	10416
450	18	11	318	867	1417	2382	3909	6535	10676	12215
500	20	14	415	1133	1851	3112	5107	8538	13948	15959
600	24	22	541	1482	2421	4069	6678	11165	18240	20869
700	28	36	1813	3639	6636	10000	19449	22768	34898	49500
750	30	37	2080	4406	9546	17010	28147	44545	66818	73426
800	32	45	2387	4791	8736	13788	20613	31395	48117	38250
900	36	260	3050	6730	12740	20220	32500	52500	79600	87500
1000	40	284	4183	8395	15307	24159	36166	55084	84425	119750
1050	42	350	4095	9040	17108	27150	43640	70500	106890	117500
1200	48	455	5365	11840	22400	30600	51200	92300	140000	154000

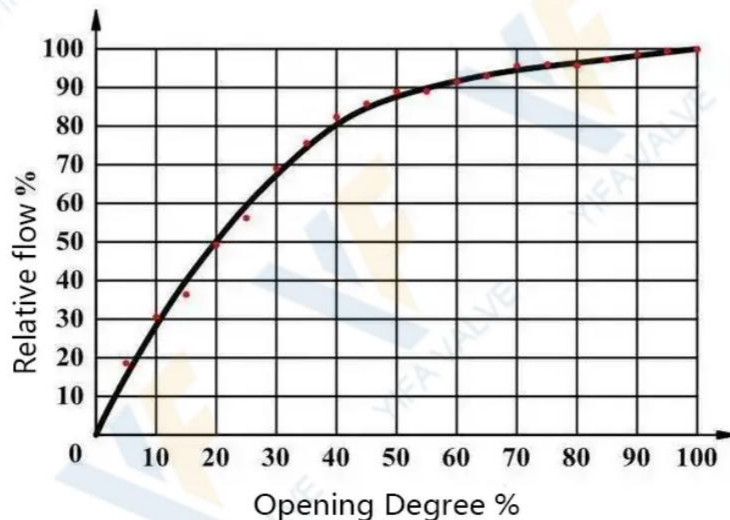

# YFD41X BUTTERFLY VALVE



## Top Flange

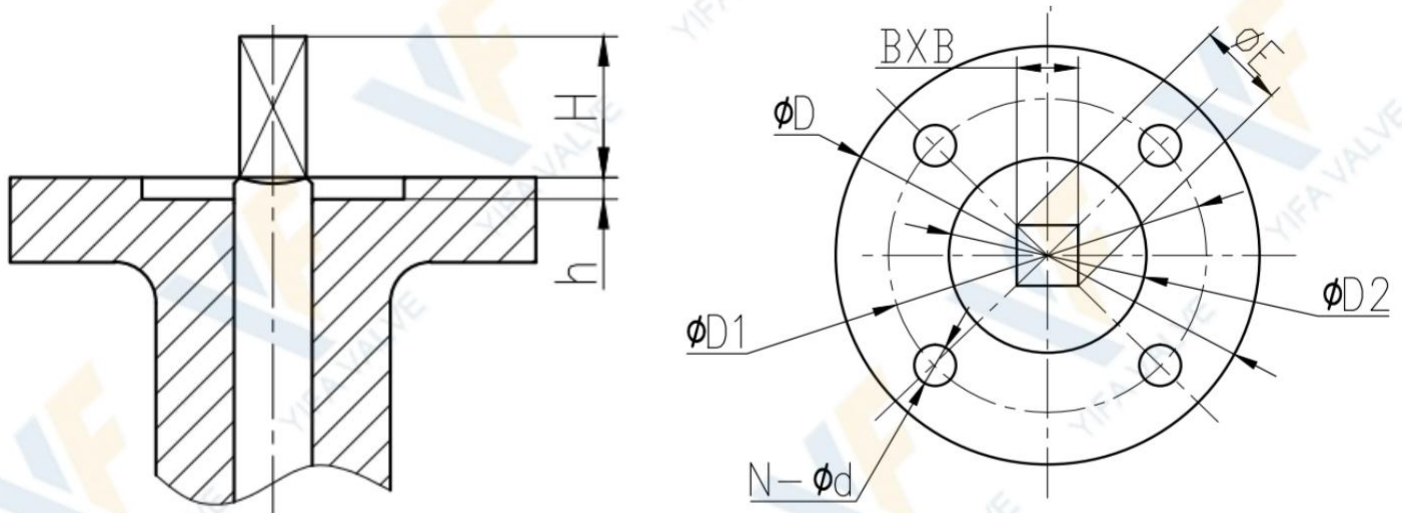

ISO5211 Top Flange DN50-DN600  
Square Stem

SIZE	φD	φD1	φD2	N-φd	h	H	BxB		ØE
							PN10	PN16	
DN50	65	50	35	4-8	4	25	9X9		12.6
DN65	65	50	35	4-8	4	25	9X9		12.6
DN80	65	50	35	4-8	4	25	9X9		12.6
DN100	90	70	55	4-10	4	28	11X11		15.8
DN125	90	70	55	4-10	4	28	14X14		18.9
DN150	90	70	55	4-10	4	28	14X14		18.9
DN200	125	102	70	4-12	4	33	17X17		22.1
DN250	125	102	70	4-12	4	33	22X22		28.45
DN300	125	102	70	4-12	4	33	22X22		31.6
DN350	125	102	70	4-12	4	45	22X22		31.6
DN400	175	140	100	4-18	5	52	27		33.15
DN450	175	140	100	4-18	5	52	27		38
DN500	175	140	100	4-18	5	64	32		41.15
DN600	210	165	130	4-22	6	70	36		50.65

# YFD41X

## BUTTERFLY VALVE



### Top Flange

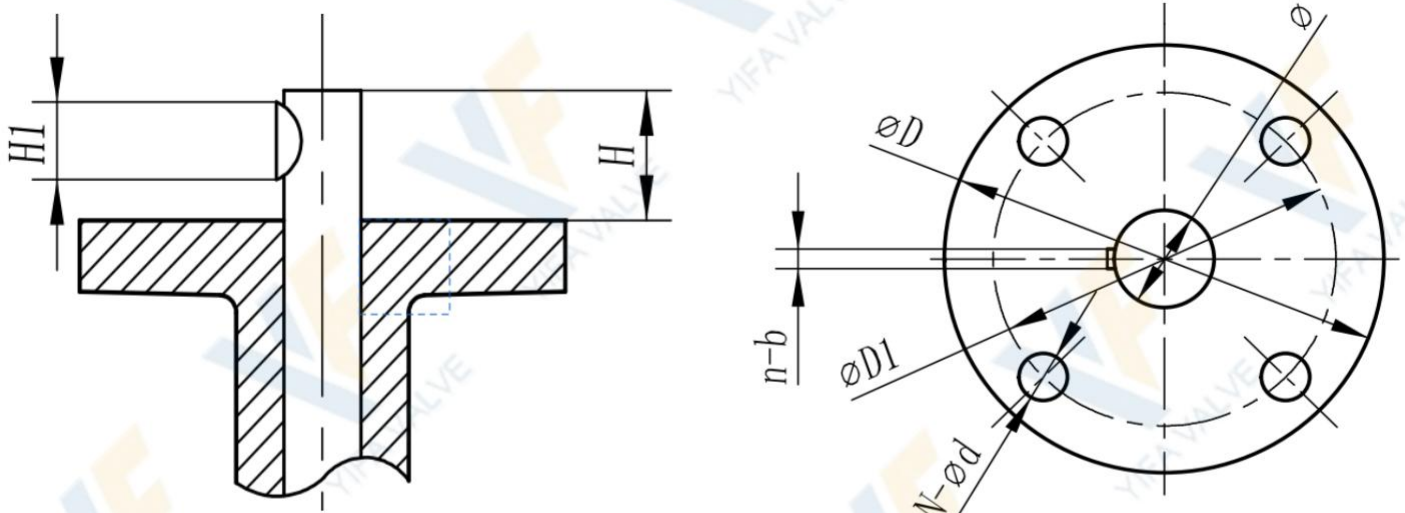

ISO5211 Top Flange DN50-DN1200  
Round Stem

DN mm	ISO5211	ØD	ØD1	N-Ød	n-b		H1	H	Ø	
					PN10	PN16			PN10	PN16
50	F05	65	50	4-8	1-3		15.7	32	12.6	
65	F05	65	50	4-8	1-3		15.7	32	12.6	
80	F05	65	50	4-8	1-3		15.7	32	12.6	
100	F07	90	70	4-10	1-5		18.6	32	15.77	
125	F07	90	70	4-10	1-5		18.6	32	18.92	
150	F07	90	70	4-10	1-5		18.6	32	18.92	
200	F10	125	102	4-12	1-5		27.4	45	22.1	
250	F10	125	102	4-12	1-8		27.4	45	28.5	
300	F10	125	102	4-12	1-8		27.4	45	31.7	
350	F10	125	102	4-12	1-8		27.4	45	31.7	
400	F14	175	140	4-18	1-10		45	52	33.15	37.95
450	F14	175	140	4-18	1-10	1-12	45	52	38.00	42.86
500	F14	175	140	4-18	1-12	1-14	55	64	41.15	45.72
550	F16	210	165	4-22	1-16		60	64	50.65	
600	F16	210	165	4-22	1-16	2-16	65	70	50.65	53.98
700	F25	300	254	8-18	2-18		85	95	63.35	
750	F25	300	254	8-18	2-18		85	95	63.35	
800	F25	300	254	8-18	2-18		85	95	63.35	
900	F25	300	254	8-18	2-20		130	130	75	
1000	F25	300	254	8-18	2-22		130	130	85	
1050	F25	300	254	8-18	2-22		150	150	85	
1100	F25	300	254	8-18	2-22		150	150	85	
1200	F30	350	298	8-22	2-28		150	150	100	

# YFD41X BUTTERFLY VALVE



## Selection for Actuator

YIFA offers butterfly valves with various actuation options. Thanks to quarter-turn operation, they are easy to use and ideal for automation. Actuation options include manual, pneumatic, electric, and hydraulic, with ON/OFF or modulating control.

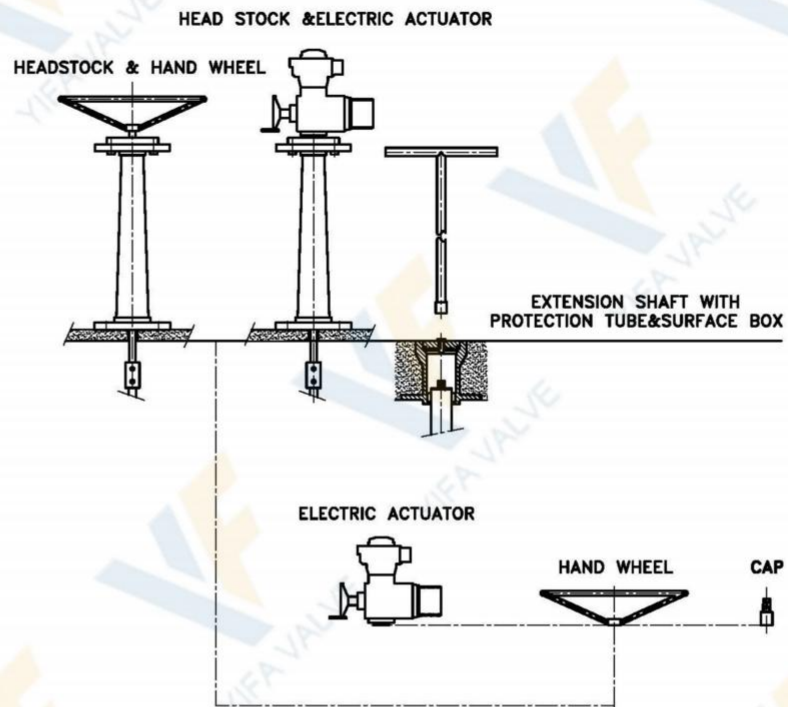

## SELECTION FOR SPARE PARTS

- Solenoid valve
- Air filter
- Limit switch
- Proximity switch
- Positioner
- Distribution box

- Hoist for platform operation

If customers have special requirements for valve stem, they shall provide the distance from platform to center of valve pipeline.

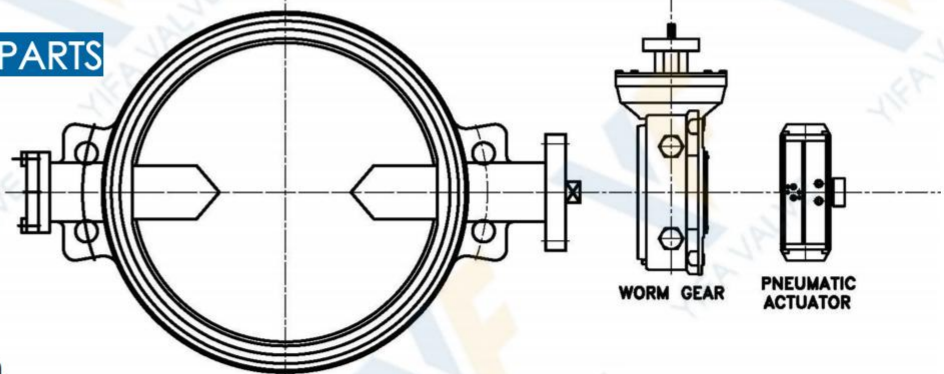

# YFD41X BUTTERFLY VALVE



## Handle

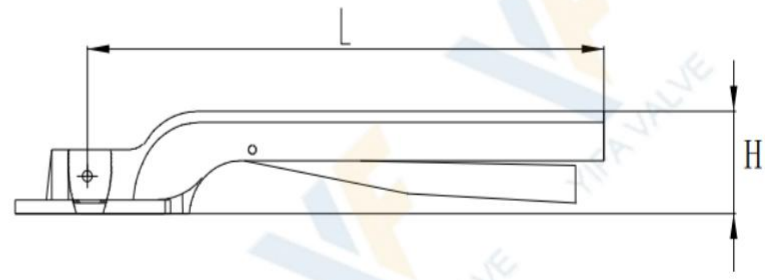
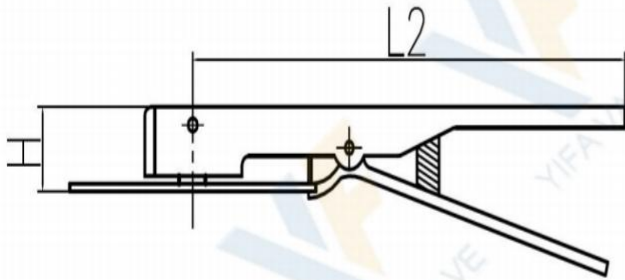

Iron/SS304 Handle

DN	H	L2	Square	TopFlange
50	27	240	9	F05
65	27	240	9	F05
80	27	240	9	F05
100	27	240	11	F07
125	27	255	14	F07
150	27	255	14	F07
200	32	360	17	F10
250	32	350	22	F10
300	32	350	22	F10

DN	H	L2	Square	TopFlange
50	60	197	9	F05
65	60	197	9	F05
80	60	197	9	F05
100	67	207	11	F07
125	72	277	14	F07
150	72	277	14	F07
200	90	324	17	F10



# YFD41X BUTTERFLY VALVE

Worm Gear Box DN40-DN350

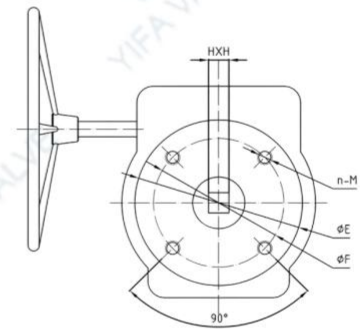
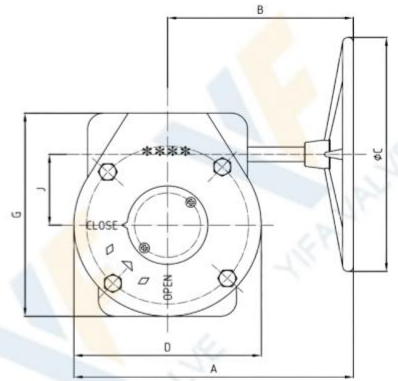

Size			Torque (N.m)	INFORMACION						REDUCTOR					ISO 5211
mm	Inch	Ratio		A	B	ØC	D	J	G	T	ØE	ØF	n-M	HXH	
DN40	1.5"	24:1	150	212	160	150	104	45	125	68	90	70	4-M8	9X9	F07
DN50	2"	24:1	150	212	160	150	104	45	125	68	90	70	4-M8	9×9	F07
DN65	2.5"	24:1	150	212	160	150	104	45	125	68	90	70	4-M8	9X9	F07
DN80	3"	24:1	150	212	160	150	104	45	125	68	90	70	4-M8	9×9	F07
DN100	4"	24:1	150	212	160	150	104	45	125	68	90	70	4-M8	11X11	F07
DN125	5"	24:1	150	212	160	150	104	45	125	68	90	70	4-M8	14X14	F07
DN150	6"	24:1	150	212	160	150	104	45	125	68	90	70	4-M8	14×14	F07
DN200	8"	30:1	500	300	227	285	145	63	170	72	125	102	4-M10	17X17	F10
DN250	10"	30:1	500	300	227	285	145	63	170	72	125	102	4-M10	22×22	F10
DN300	12"	50:1	1200	305	227	285	155	78	190	75	150	125	4-M12	22X22	F12
DN350	14"	50:1	1200	305	227	285	155	78	190	75	150	125	4-M12	22X22	F12

# YFD41X

## BUTTERFLY VALVE

Worm Gear Box DN400-DN1200

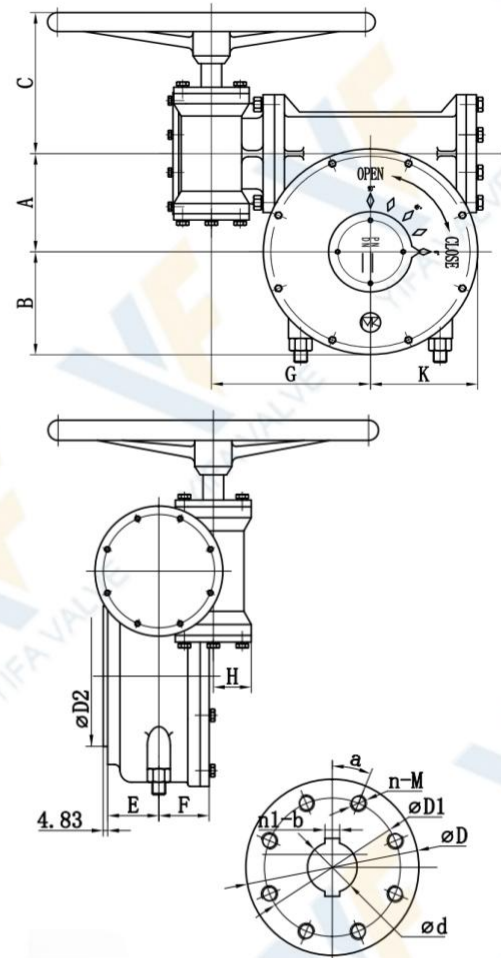

DN	Ratio	Torque (N.m)	A	B	C	D	D1	D2	h	E	F	H	G	K	φ	n-M	a	d	n1-b
DN400	560:1	2.5 × 103	100	105	148	197	140	/	/	64	60	45	172.5	105	300	4-M16	45	33.2	1-10
DN450	560:1	2.5 × 103	100	105	148	197	140	/	/	64	60	45	172.5	105	300	4-M16	45	38	1-10
DN500	560:1	2.5 × 103	100	105	148	197	140	/	/	64	60	45	172.5	105	300	4-M16	45	41.2	1-12
DN600	640:1	4 × 103	125	131	176	210	165	/	/	64	66	46.5	200	131	300	4-M20	45	50.7	1-16
DN700/ 800	704:1	8 × 103	140	146	198	300	254	200	4	74	88	55	228	146	400	8-M16	22.5	63.4	2-18
DN900	704:1	15 × 103	162	177	200	300	254	200	4	98	88	55	248	177	450	8-M18	22.5	75	2-20
DN1000	704:1	15 × 103	162	177	200	300	254	200	4	98	88	55	248	177	450	8-M18	22.5	85	2-22
DN1200	575:1	25 × 103	236	179	205	350	298	230	4	127	99	60	310	249	450	8-M20	22.5	105	2-28

# BUTTERFLY VALVE

## Installation

---

### Pre-Installation Instructions

1. Before installation, clean the pipeline by blowing with air to remove foreign objects, and flush the inner surface with clean water.
2. Carefully check whether the valve specifications match the working conditions (temperature and pressure).
3. Inspect the valve passage and sealing surfaces for any debris, and remove it if found.
4. After unpacking, install the valve as soon as possible. Do not loosen any bolts or nuts on the valve.
5. Wafer butterfly valves must be installed with suitable mating flanges (dedicated butterfly valve flanges are recommended).
6. Electric butterfly valves can be installed at any angle. However, installation upside down is not recommended for easier maintenance.

During installation, ensure that the flange faces and rubber seat are properly aligned.

Bolts must be tightened evenly. Uneven tightening may cause deformation of the rubber seat, which can obstruct the disc or lead to leakage at the stem.

### Installation Steps

1. Place the valve between the two pre-installed flanges. Ensure that all bolt holes are properly aligned.

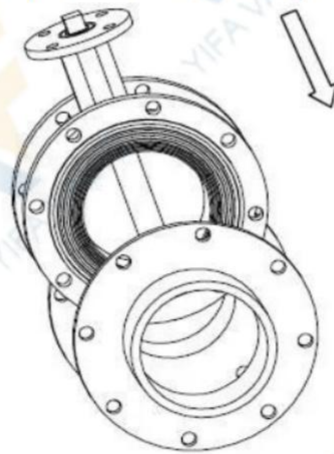

2. Insert the bolts and nuts (at least four sets) into the flange holes and lightly tighten them to adjust flange alignment.

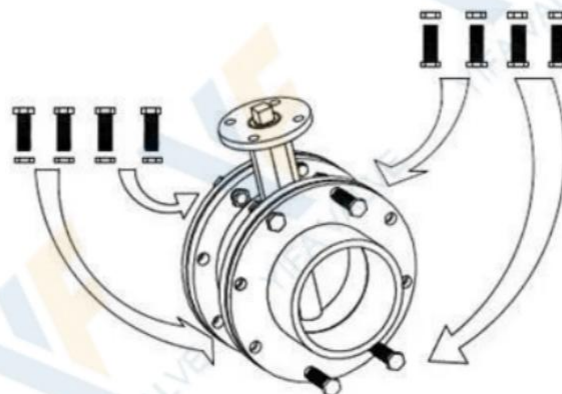

# YFD41X BUTTERFLY VALVE



## Installation

3. Fix the flanges to the pipeline by spot welding.

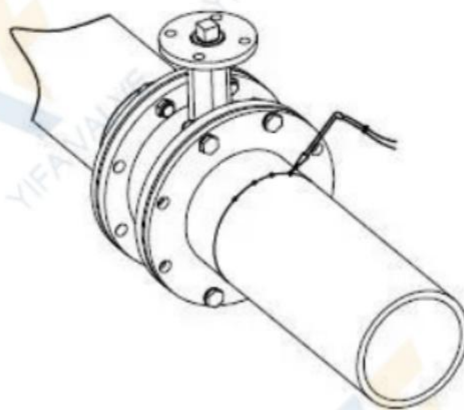

4. Remove the valve from between the flanges.

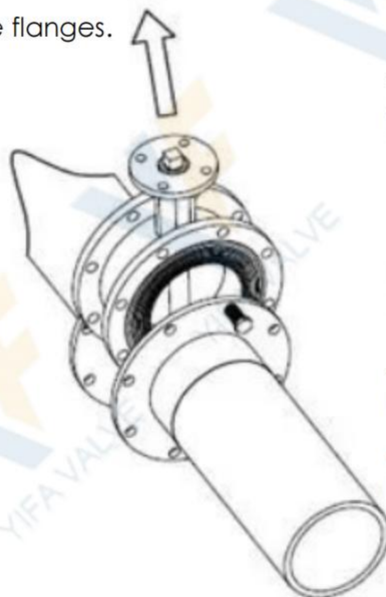

### Important Notes

The valve must be placed flat before installation. Avoid impact or collision.

Do not forcibly stretch or compress the valve during installation.

Do not disassemble the valve without proper authorization.

After installation, it is recommended to provide proper pipeline support.

Once supports are installed, they must not be removed during operation.

5. Fully weld the flanges onto the pipeline.

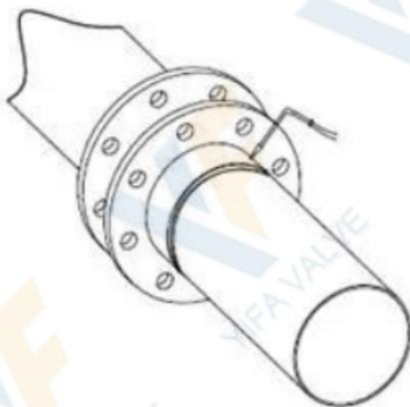

# YFD41X BUTTERFLY VALVE



## Installation

6. Install the valve after the welded joint cools down. Ensure there is sufficient clearance for the valve to move between the flanges to prevent damage to the valve, and keep the butterfly plate at a certain opening (gaskets shall be added for flange butterfly valves). Adjust the valve position and tighten all bolts (do not over-tighten them). Open the valve to ensure the butterfly plate can open and close freely, and then keep the butterfly plate slightly open.

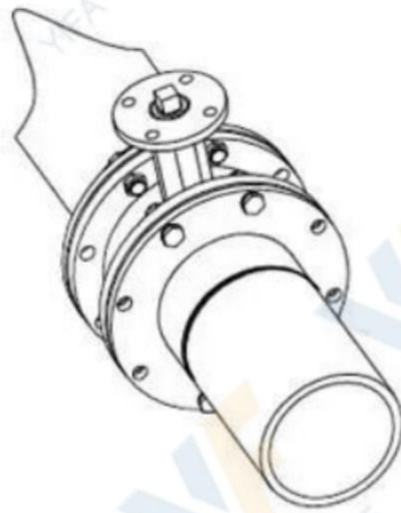

### Important Notes

The valve must be placed flat before installation. Avoid impact or collision.

Do not forcibly stretch or compress the valve during installation.

Do not disassemble the valve without proper authorization.

After installation, it is recommended to provide proper pipeline support.

Once supports are installed, they must not be removed during operation.

7. Cross-tightening: tighten all nuts.

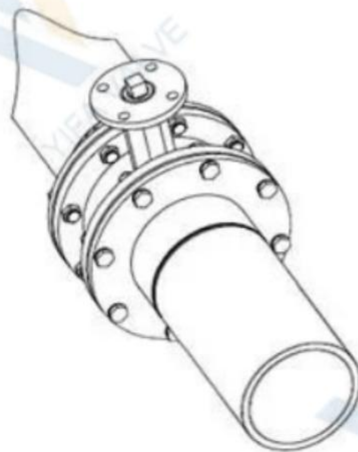

8. Confirm again that the valve operates freely, and ensure that the disc does not contact the pipe.

## Seal parts

Parts	Characteristic	Low/High Temperature		Recommended
NR	High elasticity	-20	85	-5~70
NBR	Oil resistivity	-30	100	-15~90
EPDM	Aging resistance, ozone resistance, corrosion resistance	-40	125	-25~110
HT EPDM	Same as above, added heat resistance	-40	150	-25~135
SBR (wear-resistant)	Excellent traction performance and wear resistance	-30	100	-15~80
CR (neoprene)	Oil, heat, flame, sunlight, ozone, acid and alkali resistance	-30	125	-15~100
Hypalon	Oxidation resistance, resistance to winding and cracking	-40	120	-25~110
FPM (viton)	Chemical and most oils resistance, (except ketones & esters)	-20	200	-5~150
MVQ (silicon)	High and low temperature resistance, oil, corrosion resistance	-55	200	-30~180
PU	Chemical, oil, wear, low temperature, aging resistance	-20	120	-5~90
FEP (F46)	Chemical resistance, radiation resistance	-20	150	-5~120
PTFE	Heat, cold, acid, alkali, organic solvents resistant	-60	180	-45~150
RPTFE	Corrosion resistance, low friction coefficient	-60	180	-45~150
PFA	Excellent chemical corrosion resistance, low friction coefficient	-196	200	-60~180
PPL	High temperature and chemical corrosion resistance	-60	230	-45~200
UPVC	Corrosion and pressure resistance, hygiene	-30	100	-15~80
CPVC	Corrosion and pressure resistance, hygiene	-30	110	-15~95
PVDF	Anti aging and chemical resistance	-30	100	-15~70
PEEK	High temperature and chemical resistance	-60	300	-45~260
Flexible graphite	Cold and hot resistant, corrosion resistant, self-lubricating	-200	600	-60~550
Ceramic fiber	Fire, high temperature resistance, low thermal conductivity	-200	1050	-60~950
Metal to metal	High temperature, high pressure, wear, corrosion resistance	Refer to the material		

Unit: Degree

## Inspection Standards and Requirements

Inspection Standards and Requirements							
		ISO5208:2008 / GB/T13927			API598-2004		
Shell strength	Medium temperature	5~40			5~40		
	Medium	Water, kerosene, air, suitable gas			Water, kerosene, air, suitable gas		
	Test pressure	Norminal pressure (PN)×1.5			Norminal pressure×1.5		
	Minimum duration of the test	DN	Seconds		NPS	Check valve	Others
		≤50	15		≤2"	60	15
		65~200	60		2½"~6"	60	60
≥250		180		8"~12"	60	120	
Assessment	No visible leakage allowed			No visible leakage allowed			
Back seal	Test pressure	DN	PN	Pressure	NPS	Class	Pressure
		≤80	All	0.6Mpa	All	≤300	0.4~0.7Mpa
		100~200	≤5.0	0.6Mpa			
		100~200	>5.0	PN × 1.1		>300	Class x 1.1
	≥250	All	PN × 1.1				
Assessment	No visible leakage allowed			No visible leakage allowed			
High pressure sealing test	Test pressure	DN	PN	Pressure	Class	Ductile iron	Steel
		≤80	All	PN × 1.1 (liquid)	150	1.7 Mpa	Class x 1.1
		100~200	≤5.0	0.5~0.7Mpa (air)			
		100~200	>5.0	PN × 1.1 (liquid)	300	4.4 Mpa	
		≥250	All	0.5~0.7Mpa (air)			
		Minimum duration of the test	DN	Metal seal	Resilient seal	NPS	Check valve
	≤50	15	15	≤2"	60	15	
	65~200	30	15	2½"~6"	60	60	
	250~450	60	30	8"~12"	60	120	
	≥500	120	60	≥14"	120	120	
	Assessment	Class (level)	Liquid leakage	Air leakage	NPS	Liquid & Air	Liquid & Air
		A	No visible leakage allowed (mm <sup>3</sup> /s)		≤2"	Liquid:3cm <sup>3</sup> /in. min Air:0.042m <sup>3</sup> /in.h	0 drop(bubble)/min
		B	DN x 0.01	DN x 0.3	2½"~6"		12 & 24
		C	DN x 0.03	DN x 3	8"~12"		20 & 40
	D	DN x 0.1	DN x 30	≥14"		2 & 4 / in ·min	
	Low pressure sealing test	Medium	Air, suitable gas			Air, suitable gas	
Test pressure		0.5~0.7 Mpa			0.4~0.7 Mpa		
		DN	Metal seal	Resilient seal	NPS	Check valve	Others
		≤50	15	15	≤2"	60	15
Minimum duration of the test		65~200	30	15	2½"~6"	60	60
		250~450	60	30	8"~12"	60	120
		≥500	120	60	≥14"	120	120
Assessment		Class (level)	Air leakage		NPS	Air leakage	
		A	No visible leakage allowed (mm <sup>3</sup> /s)		≤2"		0 bubble /min
		B	DN x 0.3		2½"~6"	0.042 m <sup>3</sup> /in ·h	24
	C	DN x 3		8"~12"		40	
D	DN x 30		≥14"		4 / in ·min		

## Flange connection dimensions

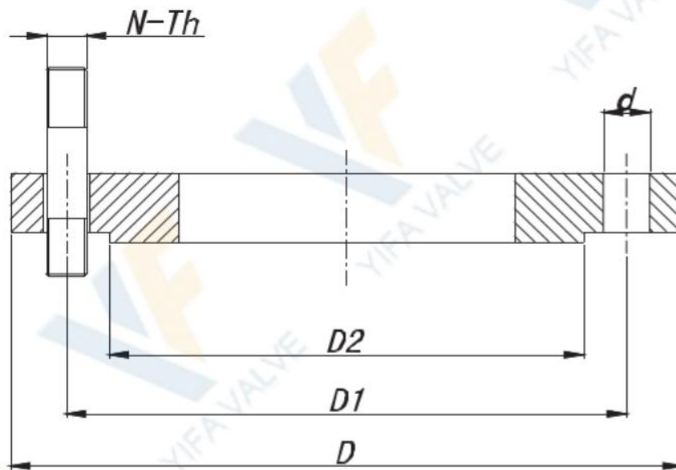

- D- Flange outer diameter
- D1- Bolt circle diameter
- D2- Diameter of sealing surface
- N-Th Bolt size
- d- Bolt hole diameter

### PN10 (DIN2632)

DN	D	D1	D2	N-Th	d
DN	D	D1	D2	N-Th	d
50	165	125	102	4-M16	Φ18
65	185	145	122	4-M16	Φ18
80	200	160	138	8-M16	Φ18
100	220	180	158	8-M16	Φ18
125	250	210	188	8-M16	Φ18
150	285	240	212	8-M20	Φ23
200	340	295	268	12-M20	Φ23
250	405	355	320	12-M24	Φ27
300	460	410	378	12-M24	Φ27
350	520	470	438	16-M24	Φ27
400	580	525	490	16-M27	Φ30
450	640	585	550	20-M27	Φ30
500	715	650	610	20-M30	Φ33
600	840	770	725	20-M33	Φ36
700	910	840	795	24-M33	Φ36
800	1025	950	900	24-M36	Φ39
900	1125	1050	1000	28-M36	Φ39
1000	1255	1170	1115	28-M39	Φ42
1200	1485	1390	1330	32-M45	Φ48
1400	1685	1590	1530	36-M45	Φ48
1600	1930	1820	1750	40-M52	Φ56
1800	2130	2020	1950	44-M52	Φ56
2000	2345	2230	2150	48-M56	Φ62

### PN16 (DIN2632)

DN	D	D1	D2	N-Th	d
DN	D	D1	D2	N-Th	d
50	165	125	102	4-M16	Φ18
65	185	145	122	4-M16	Φ18
80	200	160	138	8-M16	Φ18
100	220	180	158	8-M16	Φ18
125	250	210	188	8-M16	Φ18
150	285	240	212	8-M20	Φ23
200	340	295	268	12-M20	Φ23
250	405	355	320	12-M24	Φ27
300	460	410	378	12-M24	Φ27
350	520	470	438	16-M24	Φ27
400	580	525	490	16-M27	Φ30
450	640	585	550	20-M27	Φ30
500	715	650	610	20-M30	Φ33
600	840	770	725	20-M33	Φ36
700	910	840	795	24-M33	Φ36
800	1025	950	900	24-M36	Φ39
900	1125	1050	1000	28-M36	Φ39
1000	1255	1170	1115	28-M39	Φ42
1200	1485	1390	1330	32-M45	Φ48
1400	1685	1590	1530	36-M45	Φ48
1600	1930	1820	1750	40-M52	Φ56
1800	2130	2020	1950	44-M52	Φ56
2000	2345	2230	2150	48-M56	Φ62

## Flange connection dimensions

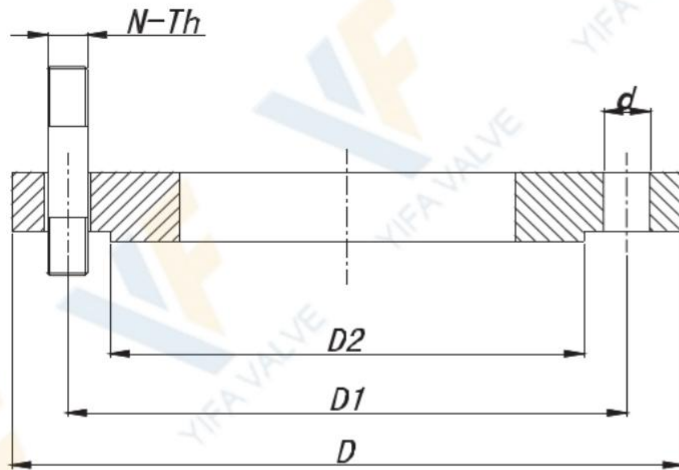

- D- Flange outer diameter
- D1- Bolt circle diameter
- D2- Diameter of sealing surface
- N-Th Bolt size
- d- Bolt hole diameter

PN10 (GB/T9113.1)

DN	D	D1	D2	N-Th	d
50	165	125	99	4-M16	Φ18
65	185	145	118	4-M16	Φ18
80	200	160	132	8-M16	Φ18
100	220	180	156	8-M16	Φ18
125	250	210	184	8-M16	Φ18
150	285	240	211	8-M20	Φ23
200	340	295	266	8-M20	Φ23
250	395	350	319	12-M20	Φ23
300	445	400	370	12-M20	Φ23
350	505	460	429	16-M20	Φ23
400	565	515	480	16-M24	Φ27
450	615	565	530	20-M24	Φ27
500	670	620	582	20-M24	Φ27
600	780	725	682	20-M27	Φ30
700	895	840	794	24-M27	Φ30
800	1015	950	901	24-M30	Φ33
900	1115	1050	1001	28-M30	Φ33
1000	1230	1160	1112	28-M33	Φ36
1200	1455	1380	1328	32-M36	Φ39

PN16 (GB/T9113.1)

DN	D	D1	D2	N-Th	d
50	165	125	99	4-M16	Φ18
65	185	145	118	4-M16	Φ18
80	200	160	132	8-M16	Φ18
100	220	180	156	8-M16	Φ18
125	250	210	184	8-M16	Φ18
150	285	240	211	8-M20	Φ23
200	340	295	266	12-M20	Φ23
250	405	355	319	12-M24	Φ27
300	460	410	370	12-M24	Φ27
350	520	470	429	16-M24	Φ27
400	580	525	480	16-M27	Φ30
450	640	585	548	20-M27	Φ30
500	715	650	609	20-M30	Φ33
600	840	770	720	20-M33	Φ36
700	910	840	794	24-M33	Φ36
800	1025	950	901	24-M36	Φ39
900	1125	1050	1001	28-M36	Φ39
1000	1255	1170	1112	28-M39	Φ42
1200	1485	1390	1328	32-M45	Φ48

## Flange and connection details

### GB/T9113.1 PN10

DN	D1	n°	M	T	●	⊕	+
50	125	4	M-16	10	2--0		-2
65	145	4	M-16	10	2--0		-2
80	160	8	M-16	12	2--4		-2
100	180	8	M-16	12	2--4		-2
125	210	8	M-16	14	2--4		-2
150	240	8	M-20	14	2--4		-2
200	295	8	M-20	14	2--4		-2
250	350	12	M-20	18	4--6		-2
300	400	12	M-20	21	4--6		-2
350	460	16	M-20	21	6--8		-2
400	515	16	M-24	25	6--8		-2
450	565	20	M-24	25	8--10		-2
500	620	20	M-24	26	8--10		-2
600	725	20	M-27	26	8--10		-2
700	840	24	M-27	22	10--12		-2
800	950	24	M-30	22	10--12		-2
900	1050	28	M-30	22	12--12		-4
1000	1160	28	M-33	22	12--12		-4
1200	1380	32	M-36	33	14--14		-4

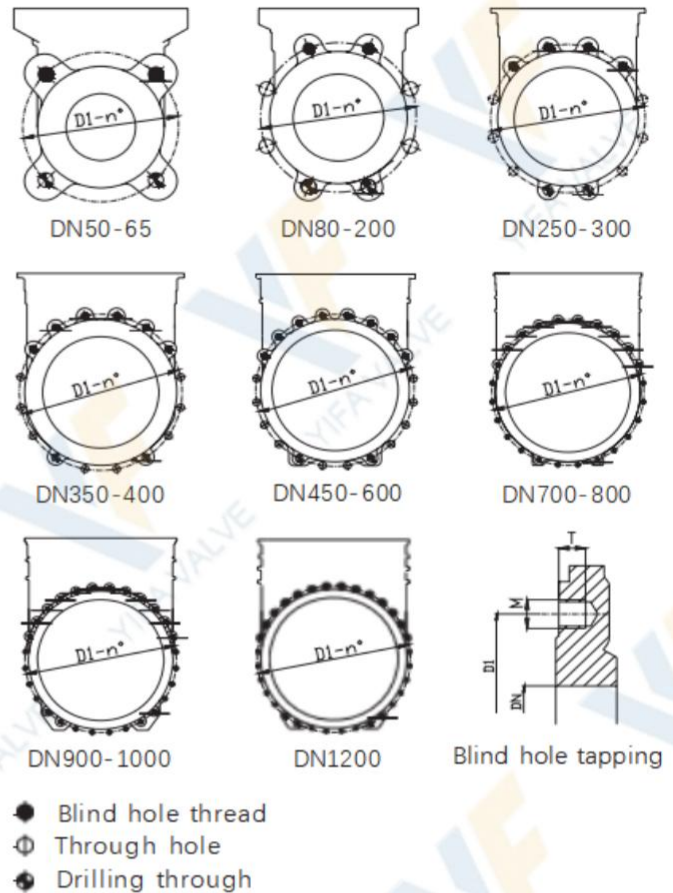

### GB/T9113.1 PN16

DN	D1	n°	M	T	●	⊕	+
50	125	4	M-16	10	2--0		-2
65	145	4	M-16	10	2--0		-2
80	160	8	M-16	12	2--4		-2
100	180	8	M-16	12	2--4		-2
125	210	8	M-16	14	2--4		-2
150	240	8	M-20	14	2--4		-2
200	295	12	M-20	14	2--4		-2
250	355	12	M-24	18	4--6		-2
300	410	12	M-24	21	4--6		-2
350	470	16	M-24	21	6--8		-2
400	525	16	M-27	25	6--8		-2
450	585	20	M-27	25	8--10		-2
500	640	20	M-30	26	8--10		-2
600	725	20	M-33	26	8--10		-2
700	840	24	M-33	22	10--12		-2
800	950	24	M-36	22	10--12		-2
900	1050	28	M-36	22	12--12		-4
1000	1170	28	M-39	22	12--12		-4
1200	1390	32	M-45	33	14--14		-4

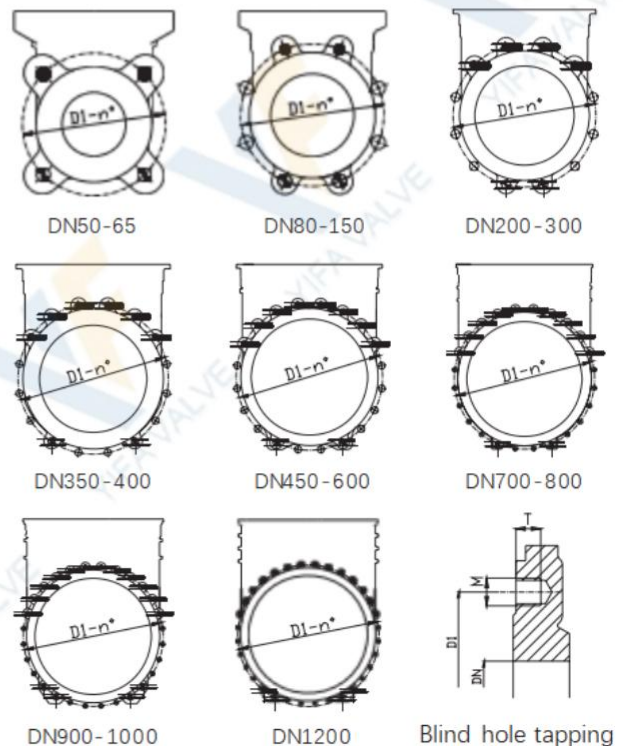

## Flange connection dimensions

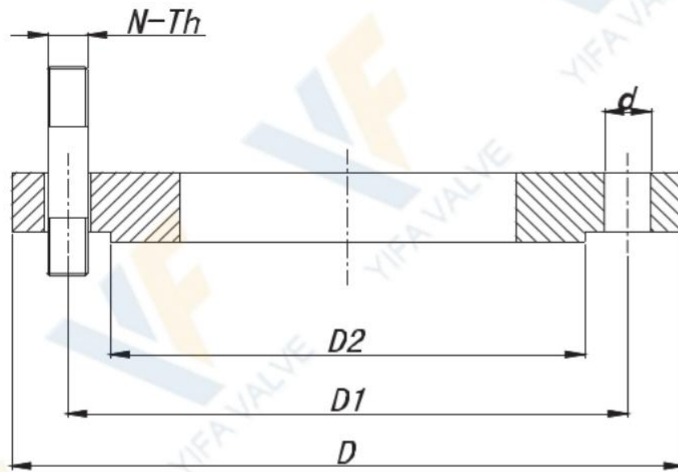

- D- Flange outer diameter
- D1- Bolt circle diameter
- D2- Diameter of sealing surface
- N-Th Bolt size
- d- Bolt hole diameter

10K (JIS B2239-2004)

150Lb (ANSI B16.5 & ASME B16.47)

DN	D	D1	D2	N-Th	d
50	155	120	96	4-M16	Φ19
65	175	140	116	4-M16	Φ19
80	185	150	126	8-M16	Φ19
100	210	175	151	8-M16	Φ19
125	250	210	182	8-M20	Φ23
150	280	240	212	8-M20	Φ23
200	330	290	262	12-M20	Φ23
250	400	355	324	12-M22	Φ25
300	445	400	368	16-M22	Φ25
350	490	445	413	16-M22	Φ25
400	560	510	475	16-M24	Φ27
450	620	565	530	20-M24	Φ27
500	675	620	585	20-M24	Φ27
550	745	680	640	20-M30	Φ33
600	795	730	690	24-M30	Φ33
650	845	780	740	24-M30	Φ33
700	905	840	800	24-M30	Φ33
750	970	900	855	24-M30	Φ33
800	1020	950	905	28-M30	Φ33
850	1070	1000	955	28-M30	Φ33
900	1120	1050	1005	28-M30	Φ33
1000	1235	1160	1110	28-M36	Φ39
1100	1345	1270	1220	28-M36	Φ39
1200	1465	1380	1325	32-M36	Φ39
1350	1630	1540	1480	36-M42	Φ45
1500	1795	1700	1635	40-M42	Φ45

DN	D	D1	D2	N-Th	d
2D	153	120.5	92	4-5/8DUNC	Φ19
2.5D	178	139.5	105	4-5/8DUNC	Φ19
3D	191	152.5	127	4-5/8DUNC	Φ19
4D	229	190.5	157	8-5/8DUNC	Φ19
5D	254	216	186	8-3/4DUNC	Φ22
6D	280	241.5	216	8-3/4DUNC	Φ22
8D	343	298.5	270	8-3/4DUNC	Φ22
10D	407	362	324	12-7/8DUNC	Φ25
12D	483	432	381	12-7/8DUNC	Φ25
14D	534	476	413	12-1DUNC	Φ29
16D	597	539.5	470	16-1DUNC	Φ29
18D	635	578	534	16-1 1/8DUNC	Φ32
20D	699	635	584	20-1 1/8DUNC	Φ32
24D	813	749.5	692	20-1 1/4DUNC	Φ35
26D	870	806.5	749	24-1 1/4DUNC	Φ35
28D	925	863.5	800	28-1 1/4DUNC	Φ35
30D	985	914.5	857	28-1 1/4DUNC	Φ35
32D	1060	978	914	28-1 1/2DUNC	Φ41
36D	1170	1086	1022	32-1 1/2DUNC	Φ41
40D	1290	1200	1124	36-1 1/2DUNC	Φ41
42D	1345	1257	1194	36-1 1/2DUNC	Φ41
44D	1405	1314	1245	40-1 1/2DUNC	Φ41
48D	1510	1422	1359	44-1 1/2DUNC	Φ41
52D	1625	1537	1461	44-1 3/4DUNC	Φ47
56D	1745	1651	1575	48-1 3/4DUNC	Φ47
60D	1855	1759	1676	52-1 3/4DUNC	Φ47

## Flange and connection details

### JIS B2239-2004 10K

DN	D1	n°	M	T	●	⊕	+
50	120	4	M-16	10	2--0		-2
65	140	4	M-16	10	2--0		-2
80	150	8	M-16	12	2--4		-2
100	175	8	M-16	12	2--4		-2
125	210	8	M-20	14	2--4		-2
150	240	8	M-20	14	2--4		-2
200	290	12	M-20	14	2--4		-2
250	355	12	M-22	18	4--6		-2
300	400	16	M-22	21	4--6		-2
350	445	16	M-22	21	6--8		-2
400	510	16	M-24	25	6--8		-2
450	565	20	M-24	25	8--10		-2
500	620	20	M-24	26	8--10		-2
600	730	24	M-30	26	8--10		-2
700	840	24	M-30	22	10--12		-2
800	950	28	M-30	22	10--12		-2
900	1050	28	M-30	22	12--12		-4
1000	1160	28	M-30	22	12--12		-4
1200	1380	32	M-36	33	14--14		-4

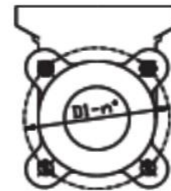

DN50-65



DN80-150

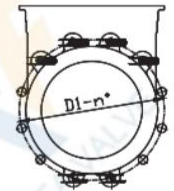

DN200-250



DN300-400



DN450-500

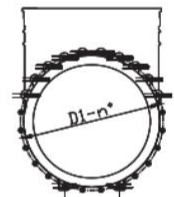

DN600-700



DN800-1000

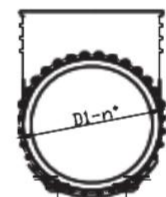

DN1200

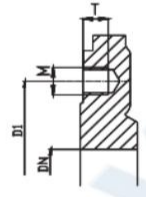

Blind hole tapping

- Blind hole thread
- ⊕ Through hole
- ⦿ Drilling through

### ANSI B16.5 & ASME B16.47 150Lb

DN	D1	n°	M	T	●	⊕	+
2"	120.5	4	5/8" UNC	10	2--0		-2
2 1/2"	139.5	4	5/8" UNC	10	2--0		-2
3"	152.5	4	5/8" UNC	12	2--4		-2
4"	190.5	8	5/8" UNC	12	2--4		-2
5"	216	8	3/4" UNC	14	2--4		-2
6"	241.5	8	3/4" UNC	14	2--4		-2
8"	298.5	8	3/4" UNC	14	2--4		-2
10"	362	12	7/8" UNC	18	4--6		-2
12"	432	12	7/8" UNC	21	4--6		-2
14"	476	12	1" UNC	21	6--8		-2
16"	540	16	1" UNC	25	6--8		-2
18"	578	16	1 1/8" UNC	25	8--10		-2
20"	635	20	1 1/8" UNC	26	8--10		-2
24"	749.5	20	1 1/4" UNC	26	8--10		-2
28"	863.5	28	1 1/4" UNC	26	10--12		-2
30"	914	28	1 1/4" UNC	22	10--12		-2
32"	978	28	1 1/2" UNC	22	12--12		-4
36"	1085.8	32	1 1/2" UNC	22	12--12		-4
40"	1200.2	36	1 1/2" UNC	30	14--14		-4

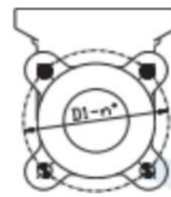

2"-3"



4"-8"

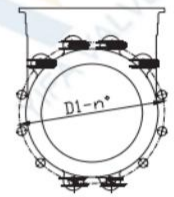

10"-14"

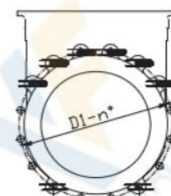

16"-18"

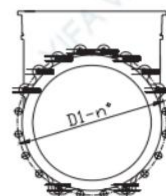

20"-24"

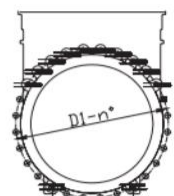

28"-32"

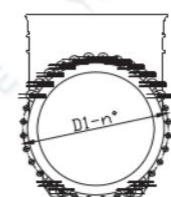

36"

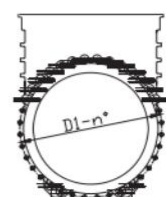

40"

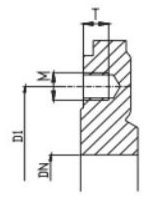

Blind hole tapping



#### ADDRESS

No.2 Road, Jinnan District  
Industrial Zone, Xiaozhan  
Town, Jinnan District, Tianjin,  
China



#### PHONE

0086 0379 69926196



#### EMAIL

[valve@yifavalves.com](mailto:valve@yifavalves.com)