

YFH44T CHECK VALVE



Product Description

YFH44T swing check valve, also known as a one-way valve or non-return valve, is an automatic control valve designed to allow medium to flow in only one direction and prevent backflow, effectively protecting the safety of pipelines and associated equipment.

With its simple structure, reliable sealing performance and flexible material selection, it is widely used in various industrial and civil pipeline systems.



Technical Data

Size range	DN40-DN400
Pressure range	PN 10-16/Class 150/JIS10K
Temperature	- 10°C to 150 °C
Design	DIN3352,MSS SP-70,JISB2071
Face to face	DIN3202 F6,ANSI B16.10,JIS B2002
Connection	EN 1092-2,ANSI B16.5,JIS B2212/B2213
Coating	Electrostatic Powder Epoxy/Spray
Testing	API598
Medium	Water,oil,Gas

Application Range

- HVAC Systems
- Pumping Stations
- Water Treatment Plants
- Reservoirs and Tanks
- Irrigation
- Industrial Applications

Related Products

- YFZ44T METAL SEAT GATE VALVE
- YFPZ73X KNIFE GATE VALVE
- YFH44X SWING CHECK VALVE



HVAC



IRRIGATION



POTABLE WATER



INDUSTRY

YFH44T

CHECK VALVE

Product Description

1. Flexible Material Selection:

The valve body can be made of gray iron or ductile iron to meet different working conditions and customer budget requirements; the standard brass seal ensures good sealing performance and long-term stability.

2. High-Quality Shaft:

The shaft is made of 2CR13 material, which has excellent hardness, wear resistance and corrosion resistance, effectively avoiding shaft deformation or rust during long-term use.

3. Multiple Standard Adaptation:

We can customize the valve according to ANSI, DIN, JIS and other international standards to meet the installation and use requirements of different countries and regions.

4. Low Flow Resistance:

The straight-through flow channel design and flexible swing valve disc reduce the flow resistance of the medium, lower the water hammer pressure, and protect the pipeline system from impact.

5. Compact Structure & Easy Installation:

The valve has the advantages of short length, small volume and light weight, saving installation space; it can be installed horizontally or vertically, and the maintenance process is simple and convenient.

6. Cost-Effective:

The reasonable material matching and mature production process make the valve have high cost performance, which is suitable for large-scale application in general working conditions.



YFH44T

CHECK VALVE

DIN3202-F6 PN16 DN40-DN300



Inspection Specification

PN	16
Seat test	1.76 Mpa
Shell test	2.4 Mpa
Temp:	-10-120°C
Medium	Water, Oil, Gas

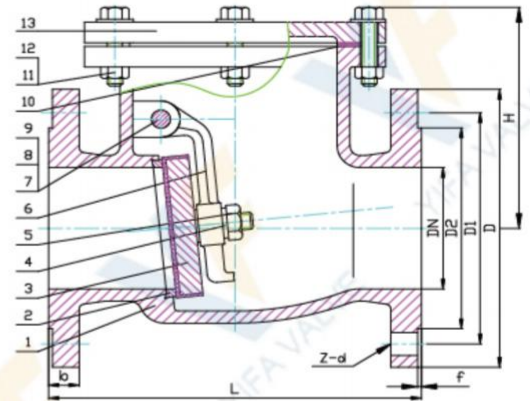

NO.	PART NAME	MATERIAL
1	BODY	GG25/GGG50
2	BODY SEAT RING	BRASS
3	DISC	GG25/GGG50/+ BRASS
4	WASHER	CARBON STEEL
5	LOCKING NUT	CARBON STEEL
6	ARM	DUCTILE IRON
7	HING PIN	STAINLESS STEEL
8	PLUG	CARBON STEEL
9	GASKET	NYL
10	GASKET	NBR
11	BOLT	CARBON STEEL
12	NUT	CARBON STEEL
13	BONNET	GG25/GGG50

DN	D	D1	D2	L	b	f	Z-d	H
Ø40	Ø150	Ø110	Ø84	180	18	3	4-Ø18	120
Ø50	Ø165	Ø125	Ø99	200	20	3	4-Ø18	137
Ø65	Ø185	Ø145	Ø118	240	20	3	4-Ø18	147
Ø80	Ø200	Ø160	Ø132	260	22	3	8-Ø18	159
Ø100	Ø220	Ø180	Ø156	300	24	3	8-Ø18	180
Ø125	Ø250	Ø210	Ø184	350	26	3	8-Ø18	203
Ø150	Ø285	Ø240	Ø211	400	26	3	8-Ø22	223
Ø200	Ø340	Ø295	Ø266	500	30	3	12-Ø22	258
Ø250	Ø405	Ø355	Ø319	600	32	3	12-Ø26	290
Ø300	Ø460	Ø410	Ø370	700	32	4	12-Ø26	325
Ø350	Ø520	Ø470	Ø429	800	36	4	16-Ø26	361

YFH44T

CHECK VALVE

BS5153 PN16 DN40-DN300

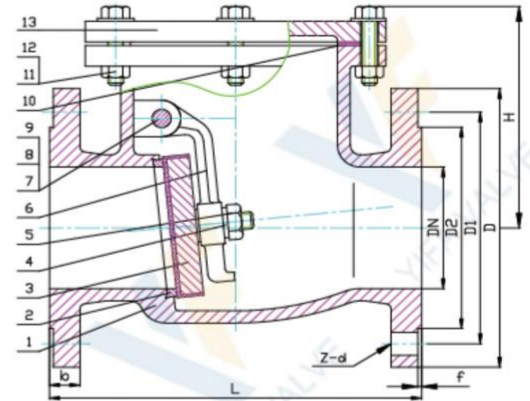

Inspection Specification

PN	16
Seat test	1.76 Mpa
Shell test	2.4 Mpa
Temp:	-10-150°C
Medium	Water, Oil, Gas

NO.	PART NAME	MATERIAL
1	BODY	GG25/GGG50
2	BODY SEAT RING	BRASS
3	DISC	GG25/GGG50/+ BRASS
4	WASHER	CARBON STEEL
5	LOCKING NUT	CARBON STEEL
6	ARM	DUCTILE IRON
7	HING PIN	STAINLESS STEEL
8	PLUG	CARBON STEEL
9	GASKET	NYL
10	GASKET	NBR
11	BOLT	CARBON STEEL
12	NUT	CARBON STEEL
13	BONNET	GG25/GGG50

DN	D	D1	L	f	b	Z-d	H
Ø40	Ø150	Ø110	165	3	15	4-Ø18	120
Ø50	Ø165	Ø125	203	3	16	4-Ø18	137
φ65	Ø185	Ø145	216	3	18	4-Ø18	147
Ø80	Ø200	Ø160	241	3	19	8-Ø18	159
Ø100	Ø220	Ø180	292	3	24	8-Ø18	180
Ø125	Ø250	Ø210	330	3	24	8-Ø18	203
Ø150	Ø285	Ø240	356	3	26	8-Ø22	223
Ø200	Ø340	Ø295	495	3	29	12-Ø22	258
Ø250	Ø405	Ø355	622	3	30	12-Ø26	290
Ø300	Ø460	Ø410	698	4	32	12-Ø26	325

YFH44T

CHECK VALVE

ANSI CLASS125 DN40-DN400

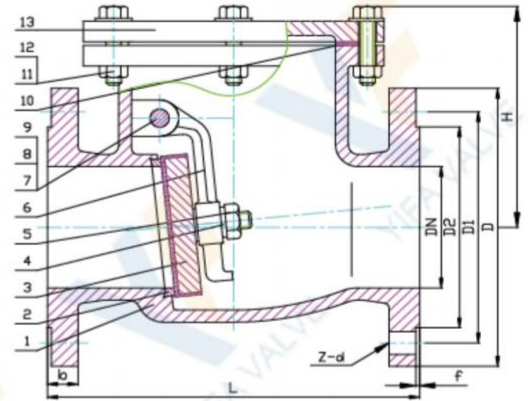

NO.	PART NAME	MATERIAL
1	BODY	GG25/GGG50
2	BODY SEAT RING	BRASS
3	DISC	GG25/GGG50/+ BRASS
4	WASHER	CARBON STEEL
5	LOCKING NUT	CARBON STEEL
6	ARM	DUCTILE IRON
7	HING PIN	STAINLESS STEEL
8	PLUG	CARBON STEEL
9	GASKET	NYL
10	GASKET	NBR
11	BOLT	CARBON STEEL
12	NUT	CARBON STEEL
13	BONNET	GG25/GGG50

Inspection Specification

PN	16
Seat test	1.76 Mpa
Shell test	2.4 Mpa
Temp:	-10-120°C
Medium	Water,Oil, Gas

DN	D	D1	L	k	Z-d	H
Ø40	Ø127	Ø98.5	165	15	4-Ø16	120
Ø50	Ø152	Ø120.5	203	16	4-Ø19	137
φ65	Ø178	Ø139.5	216	18	4-Ø19	147
Ø80	Ø191	Ø152.5	241	19	4-Ø19	159
Ø100	Ø229	Ø190.5	292	24	8-Ø19	180
Ø125	Ø254	Ø216	330	24	8-Ø22	203
Ø150	Ø279	Ø241.5	356	26	8-Ø22	223
Ø200	Ø343	Ø298.5	495	29	8-Ø22	258
Ø250	Ø406	Ø362	622	30	12-Ø25	290
Ø300	Ø483	Ø432	698	32	12-Ø25	325
Ø350	Ø533	Ø476	787	35	12-Ø29	361
Ø400	Ø597	Ø540	914	37	16-Ø29	388

YFH44T

CHECK VALVE

JIS10K DN40-DN300

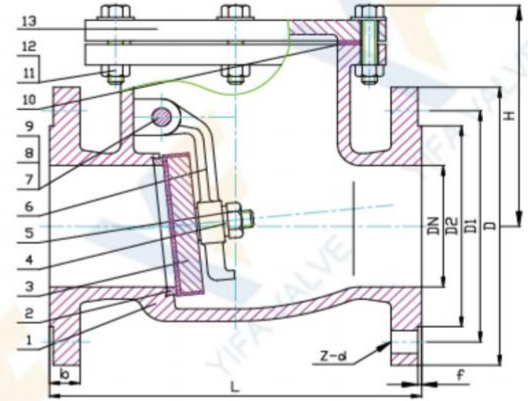

NO.	PART NAME	MATERIAL
1	BODY	GG25/GGG50
2	BODY SEAT RING	BRASS
3	DISC	GG25/GGG50/+ BRASS
4	WASHER	CARBON STEEL
5	LOCKING NUT	CARBON STEEL
6	ARM	DUCTILE IRON
7	HING PIN	STAINLESS STEEL
8	PLUG	CARBON STEEL
9	GASKET	NYL
10	GASKET	NBR
11	BOLT	CARBON STEEL
12	NUT	CARBON STEEL
13	BONNET	GG25/GGG50

Inspection Specification

PN	16
Seat test	1.76 Mpa
Shell test	2.4 Mpa
Temp:	-10-120°C
Medium	Water, Oil, Gas

DN	D	D1	L	k	Z-d	H
Ø40	Ø140	Ø98.5	165	15	4-Ø16	120
Ø50	Ø155	Ø120.5	203	16	4-Ø19	137
φ65	Ø175	Ø139.5	216	18	4-Ø19	147
Ø80	Ø185	Ø152.5	241	19	4-Ø19	159
Ø100	Ø210	Ø190.5	292	24	8-Ø19	180
Ø125	Ø250	Ø216	330	24	8-Ø22	203
Ø150	Ø280	Ø241.5	356	26	8-Ø22	223
Ø200	Ø330	Ø298.5	495	29	8-Ø22	258
Ø250	Ø400	Ø362	622	30	12-Ø25	290
Ø300	Ø445	Ø432	698	32	12-Ø25	325

YFH44T

CHECK VALVE



Installation

1. **Preparation & Inspection**

- Inspect the valve before installation to ensure no damage, debris, or foreign objects are present inside the body or on sealing surfaces.
- Verify that the valve model, size, pressure rating, and applicable standard (DIN/ANSI/JIS/GB) match the pipeline requirements.
- Confirm the pipeline is clean and free of welding slag, rust, or other impurities that could damage the valve seat.

2. **Installation Orientation**

- Install the valve in accordance with the flow direction arrow marked on the valve body.
- For horizontal pipelines: Mount the valve with the cover facing upward, ensuring the swing disc can move freely.
- For vertical pipelines: Install the valve with the flow direction upward.
- The valve can be installed in any position where the disc will not get stuck, but avoid inverted installation if possible.

3. **Connection & Tightening**

- Align the valve flanges with the pipeline flanges and insert a suitable gasket between them.
- Tighten the flange bolts evenly and diagonally to avoid uneven stress and gasket damage.
- Do not use the valve as a support point for the pipeline; ensure proper pipeline support to prevent excessive load on the valve.

4. **Commissioning & Testing**

- After installation, perform a pressure test of the pipeline to check for leaks at the valve connection points.
- Ensure the valve operates smoothly under normal working pressure and temperature.
- Check for abnormal noise or vibration during initial operation, which may indicate improper installation or debris.

CHECK VALVE

Precautions / Important Notes

Important Safety & Maintenance Notes

- ****Working Conditions****: The valve is designed for clean media (water, steam, light oil). Do not use it for media with solid particles, fibers, or corrosive substances unless specially modified.
- ****Temperature & Pressure****: Do not exceed the rated pressure and temperature specified on the valve nameplate.
- ****Sealing Surfaces****: Avoid scratching or damaging the brass sealing face during installation or maintenance, as this will cause leakage.
- ****Regular Maintenance****:
 - Periodically inspect the 2CR13 shaft, disc, and sealing components for wear, corrosion, or sticking.
 - For long-term shutdown, drain any residual water inside the valve to prevent freezing or corrosion.
- ****Repair****: If leakage occurs, check the gasket, flange connection, or sealing surface. Disassembly and repair should only be performed by qualified personnel.
- ****Handling****: Do not drop, strike, or apply excessive force to the valve during transportation and installation.

SWING CHECK VALVE INSTALLATION ORIENTATION DIAGRAM

HORIZONTAL INSTALLATION (✓ RECOMMENDED)

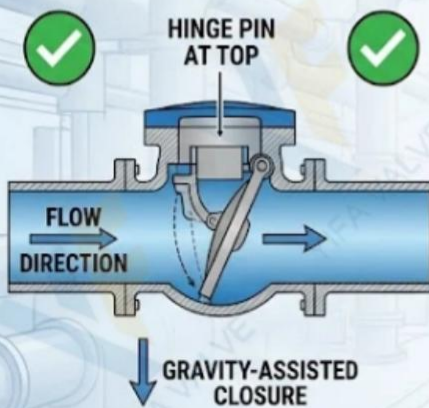

Hinge pin must be oriented at the top. Gravity helps close the valve when flow stops, ensuring a reliable seal.

VERTICAL INSTALLATION (✓ ACCEPTABLE: UPWARD FLOW)

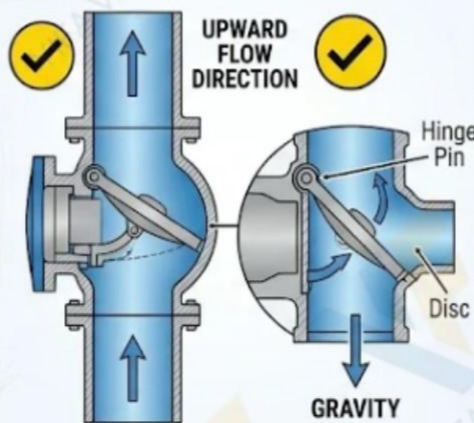

Suitable only for applications with flow directed upwards. Disc swings open with flow and closes aided by gravity.

VERTICAL INSTALLATION (✗ PROHIBITED: DOWNWARD FLOW)

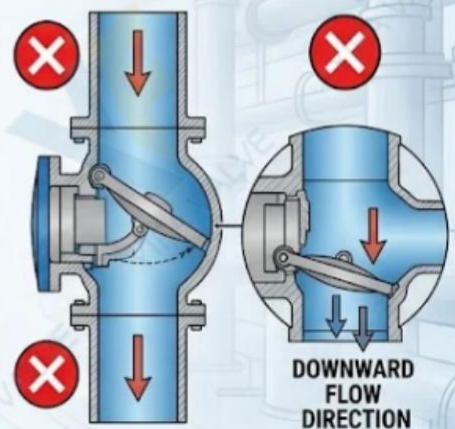

Not recommended. Gravity may force disc to remain partially or fully open, defeating backflow prevention. Water hammer risk.

Material Table-Metal

PARTS	ASME	DIN/EN	Cr	Ni	Mo	Ti	Temp.Range
	A216 WCB	GS-20 Mn 5	0.5	0.5	0.2	-	-29~425
	A216WCC	G20Mn5	0.5	0.5	0.2	-	-29~425
	A217 WC1		0.35	0.5	0.45~0.65		≤455
	A217 WC5		0.5~0.9	0.6~1	0.9~1.2	-	≤565
	A217 WC6	GS 17CrMo55	1~1.5		0.45~0.65		≤595
	A217 WC9		2~2.75	-	0.9~1.2	-	≤595
	A217 C5		4~6.5		0.45~0.65	-	≤650
	A217 C12		8~10	-	0.9~1.2	-	≤650
	A296 CA15	1.4006,1.4008	11.5~14	1	0.5	-	-20~480
	A351 CF8	G-X5CrNi ¹⁸ -10	18~21	8~11	0.05	-	≤458(540)
	A351 CF8M	X5CrNiMo18-10	18~21	9~13	2~3	-	≤425(540)
	A351 CF3	X2CrNiMo18-10	17~21	8~12	0.5	-	≤425
	A351 CF3M	GX10CrNiMo18-9	17~21	9~13	2~3		≤455
Casting	Aisi 321	X10CrNiTi18-9,1.4541	17~19	9~12	-	0.5	≤700/540
	Aisi904L	X1NiCrMoCuN25-20-6,1.4539	19~21	24~26	-		-165~600
	Aisi 316Ti	X6CrNiMoTi17-12-2	16~18	10~14	-	0.7	-165~600
	Aisi 310S	X8CrNi25-21,1.4845	24~26	19~22	-	-	≤850
	A352 LCB		-	-	-	-	-46~345
	A352 LCC		-	-	-	-	-46~345
	A352 LC1	G20Mo5,1.5419	-	-	-	-	-59~345
	A352 LC2			2~3	-		-73~200
	A352 LC3		-	3~4	-	-	-101~200
	A105(N)	C21,1.0432,S+35.8	0.3	0.4	0.12		≤450
	A350 LF1		-	-	-	-	-46~425
	A350 LF2			-			-60
	A350 LF3	10Ni14,1.5637	-	3.25~3.75	-		-101~345
	A516 Gr70	1.0539,1.0545			-	-	-46~425

Material Table-Metal

PARTS	ASME	DIN/EN	Cr	Ni	Mo	Ti	Temp.Range
Forging	A 182 F304	174,401.4301	18~20	8~11	-	-	≤800/540
	A 182 F321	X10CrNiTi18-9,1.4541	17~21	9~12	-	0.7	≤800/540
	A 182 F316	174,401.4401	16~18	10~14	2~3	-	800/540
	A 182 F316L	174,401.4404	16~18	10~15	2~3	-	≤450
	A 182 F304L	174,401.4306	18~20	8~13	-	-	≤425
	A 182F310		24~26	19~22			-29~800
	Duplex2205	X2CrNiMoN22-5-3,1.4462	21~24	4.5~6.5	2.5~3.5	-	≤450
	Duplex2304	X2CrNiN23-4,1.4362	21.5~24.5	3~5.5	0.05~0.6	-	≤425
	Duplex2507	X2CrNiMoN25-7-4,1.4410	24~26	6~8	3~5	-	-40~315
	A 182 F51	X2 CrNiMoN 22-5-3,1.4462	21~23	4.5~6.5	2.5~3.5	-	-40~315
	A 182 F1	1.5Mo3,1.5415	-	-	0.44~0.65	-	≤470
	A 182 F2	1.7335,1.7337	0.5~0.81	-	0.44~0.65	-	≤540
	A 182 F11	13CrMo4-4,1.7335	1~1.5	-	0.44~0.65	-	≤545
	A 182F22	10CrMo9-10,1.7380		0.87~1.13		-	≤550
	A 182 F12	13CrMo4-5,1.7335	0.8~1.25	-	0.44~0.65	-	≤545
	A 182 F9	X12CrMo 9-1,1.7386	8~10	-	0.9~1.1	-	≤673
	A 182 F91	1.4903,1.7332	8~9.5	0.4	0.85~1.05	-	≤673
	A 182 F5		4~6.5	0.5	0.44~0.65	-	≤550
	A 182F6a	X10Cr13	11.5~13.5	0.5	-	-	-101~480
	A 182 F44	X1CRNiMoCuN20-18-7,1.4547	19.5~20.5	17.5~18.5	6~6.5	-	≤540
Rod	Aisi 410	X12CrN13,1.4006	11.5~13.5	0.6	-	-	-101~480
	Aisi 416	X20Cr13	12~14	-	-	-	-38~350
	Aisi 420	X20Cr13	12~14	-	-	-	-101~480
	Aisi 430	X6Cr17	16~18	-	-	-	-101~480
	Aisi431	Z15CN16-02,1.4057	16~18	1.5~2.5	-	0.2	-38~425
	A276 XM-19	GX4CrNiMnN22-12-5,1.3964	20.5~23.5	11.5~13.5	1.5~3		≤550
	A 193 B7		0.75~1.2		0.15~0.25		-45.6~510
	A 193 B7M		0.75~1.2		0.15~0.25	-	-20~510
	A 193 B16		0.8~1.15	-	0.5~0.65	-	-10~600
	A 320 L7		0.8~1	-	0.15~0.25	-	-101~550
	A 320 B8		18~20	8~10.5	-	-	254~700
	A 320 B8A		18~20	8~10.5	-	-	254~700
A 320 B8M		16~18	10~14	-	-	254~816	
A 320 B8T		17~19	9~12	2~3	-	196~700	
Fasteners	A 1942H		-	-	-	-	-38~450
	A 1946		11.5~13.5	-	-	-	-101~480
	A 1948,8A		8~10.5	18~20	-	-	-254~800
	A 1948M,8MA		16~18	10~14	2~3	-	-254~816
	A 1948T,8TA		17~19	9~12	-	-	0.3~0.6 -196~700
	D507Mo		10~16	6	2.5	-	≤450
	Alloy 20		19~21	32~38	2~3	-	≤427
	Alloy 904L		19~23	23~28	4~5	-	≤700
Surfacing welding	Uranus B-6		20.5	25.5	4.5	-	≤700
	Lewmet 25		29	-	4.5	-	≤700
	Stellite Alloy 6		27~32	3	1	-	≤700
	Inconel Alloy 625		20~23	58	8~10	0.4	≤700
	Hastelloy AlloyC-276		15.5	-	16	-	≤700

Seal parts

Parts	Characteristic	Low/High Temperature		Recommended
NR	High elasticity	-20	85	-5~70
NBR	Oil resistivity	-30	100	-15~90
EPDM	Aging resistance, ozone resistance, corrosion resistance	-40	125	-25~110
HT EPDM	Same as above, added heat resistance	-40	150	-25~135
SBR (wear-resistant)	Excellent traction performance and wear resistance	-30	100	-15~80
CR (neoprene)	Oil, heat, flame, sunlight, ozone, acid and alkali resistance	-30	125	-15~100
Hypalon	Oxidation resistance, resistance to winding and cracking	-40	120	-25~110
FPM (viton)	Chemical and most oils resistance, (except ketones & esters)	-20	200	-5~150
MVQ (silicon)	High and low temperature resistance, oil, corrosion resistance	-55	200	-30~180
PU	Chemical, oil, wear, low temperature, aging resistance	-20	120	-5~90
FEP (F46)	Chemical resistance, radiation resistance	-20	150	-5~120
PTFE	Heat, cold, acid, alkali, organic solvents resistant	-60	180	-45~150
RPTFE	Corrosion resistance, low friction coefficient	-60	180	-45~150
PFA	Excellent chemical corrosion resistance, low friction coefficient	-196	200	-60~180
PPL	High temperature and chemical corrosion resistance	-60	230	-45~200
UPVC	Corrosion and pressure resistance, hygiene	-30	100	-15~80
CPVC	Corrosion and pressure resistance, hygiene	-30	110	-15~95
PVDF	Anti aging and chemical resistance	-30	100	-15~70
PEEK	High temperature and chemical resistance	-60	300	-45~260
Flexible graphite	Cold and hot resistant, corrosion resistant, self-lubricating	-200	600	-60~550
Ceramic fiber	Fire, high temperature resistance, low thermal conductivity	-200	1050	-60~950
Metal to metal	High temperature, high pressure, wear, corrosion resistance	Refer to the material		

Unit: Degree

Inspection Standards and Requirements

Inspection Standards and Requirements							
		ISO5208:2008 / GB/T13927			API598-2004		
Shell strength	Medium temperature	5~40			5~40		
	Medium	Water, kerosene, air, suitable gas			Water, kerosene, air, suitable gas		
	Test pressure	Norminal pressure (PN)×1.5			Norminal pressure×1.5		
	Minimum duration of the test	DN	Seconds		NPS	Check valve	Others
		≤50	15		≤2"	60	15
		65~200	60		2½"~6"	60	60
≥250		180		8"~12"	60	120	
Assessment	No visible leakage allowed			No visible leakage allowed			
Back seal	Test pressure	DN	PN	Pressure	NPS	Class	Pressure
		≤80	All	0.6Mpa	All	≤300	0.4~0.7Mpa
		100~200	≤5.0	0.6Mpa			
		100~200	>5.0	PN × 1.1		>300	Class x 1.1
	≥250	All	PN × 1.1				
Assessment	No visible leakage allowed			No visible leakage allowed			
High pressure sealing test	Test pressure	DN	PN	Pressure	Class	Ductile iron	Steel
		≤80	All	PN × 1.1 (liquid)	150	1.7 Mpa	Class x 1.1
		100~200	≤5.0	0.5~0.7Mpa (air)			
		100~200	>5.0	PN × 1.1 (liquid)	300	4.4 Mpa	
		≥250	All	0.5~0.7Mpa (air)			
		Minimum duration of the test	DN	Metal seal	Resilient seal	NPS	Check valve
	≤50	15	15	≤2"	60	15	
	65~200	30	15	2½"~6"	60	60	
	250~450	60	30	8"~12"	60	120	
	≥500	120	60	≥14"	120	120	
	Assessment	Class (level)	Liquid leakage	Air leakage	NPS	Liquid & Air	Liquid & Air
		A	No visible leakage allowed (mm ³ /s)		≤2"	Liquid:3cm ³ /in. min Air:0.042m ³ /in.h	0 drop(bubble)/min
		B	DN x 0.01	DN x 0.3	2½"~6"		12 & 24
		C	DN x 0.03	DN x 3	8"~12"		20 & 40
	D	DN x 0.1	DN x 30	≥14"		2 & 4 / in ·min	
	Low pressure sealing test	Medium	Air, suitable gas			Air, suitable gas	
Test pressure		0.5~0.7 Mpa			0.4~0.7 Mpa		
		DN	Metal seal	Resilient seal	NPS	Check valve	Others
		≤50	15	15	≤2"	60	15
Minimum duration of the test		65~200	30	15	2½"~6"	60	60
		250~450	60	30	8"~12"	60	120
		≥500	120	60	≥14"	120	120
Assessment		Class (level)	Air leakage		NPS	Air leakage	
		A	No visible leakage allowed (mm ³ /s)		≤2"		0 bubble /min
		B	DN x 0.3		2½"~6"	0.042 m ³ /in ·h	24
	C	DN x 3		8"~12"		40	
D	DN x 30		≥14"		4 / in ·min		

Flange connection dimensions

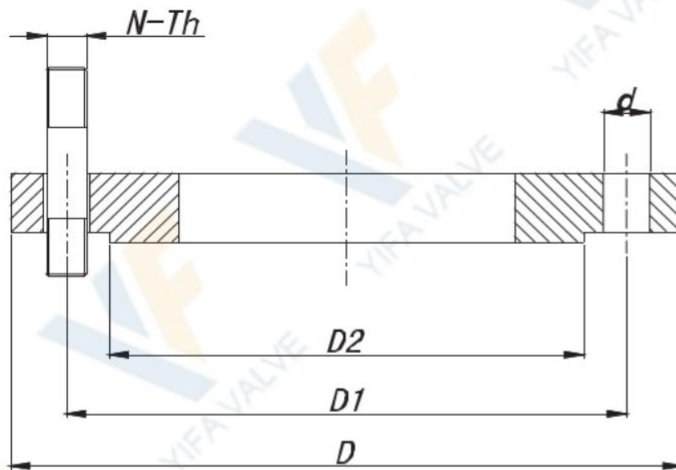

- D- Flange outer diameter
- D1- Bolt circle diameter
- D2- Diameter of sealing surface
- N-Th Bolt size
- d- Bolt hole diameter

PN10 (DIN2632)

DN	D	D1	D2	N-Th	d
50	165	125	102	4-M16	Φ18
65	185	145	122	4-M16	Φ18
80	200	160	138	8-M16	Φ18
100	220	180	158	8-M16	Φ18
125	250	210	188	8-M16	Φ18
150	285	240	212	8-M20	Φ23
200	340	295	268	12-M20	Φ23
250	405	355	320	12-M24	Φ27
300	460	410	378	12-M24	Φ27
350	520	470	438	16-M24	Φ27
400	580	525	490	16-M27	Φ30
450	640	585	550	20-M27	Φ30
500	715	650	610	20-M30	Φ33
600	840	770	725	20-M33	Φ36
700	910	840	795	24-M33	Φ36
800	1025	950	900	24-M36	Φ39
900	1125	1050	1000	28-M36	Φ39
1000	1255	1170	1115	28-M39	Φ42
1200	1485	1390	1330	32-M45	Φ48
1400	1685	1590	1530	36-M45	Φ48
1600	1930	1820	1750	40-M52	Φ56
1800	2130	2020	1950	44-M52	Φ56
2000	2345	2230	2150	48-M56	Φ62

PN16 (DIN2632)

DN	D	D1	D2	N-Th	d
50	165	125	102	4-M16	Φ18
65	185	145	122	4-M16	Φ18
80	200	160	138	8-M16	Φ18
100	220	180	158	8-M16	Φ18
125	250	210	188	8-M16	Φ18
150	285	240	212	8-M20	Φ23
200	340	295	268	12-M20	Φ23
250	405	355	320	12-M24	Φ27
300	460	410	378	12-M24	Φ27
350	520	470	438	16-M24	Φ27
400	580	525	490	16-M27	Φ30
450	640	585	550	20-M27	Φ30
500	715	650	610	20-M30	Φ33
600	840	770	725	20-M33	Φ36
700	910	840	795	24-M33	Φ36
800	1025	950	900	24-M36	Φ39
900	1125	1050	1000	28-M36	Φ39
1000	1255	1170	1115	28-M39	Φ42
1200	1485	1390	1330	32-M45	Φ48
1400	1685	1590	1530	36-M45	Φ48
1600	1930	1820	1750	40-M52	Φ56
1800	2130	2020	1950	44-M52	Φ56
2000	2345	2230	2150	48-M56	Φ62

Flange connection dimensions

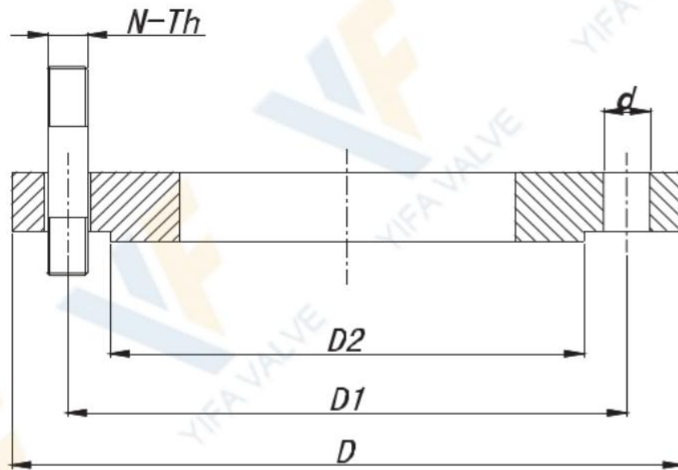

- D- Flange outer diameter
- D1- Bolt circle diameter
- D2- Diameter of sealing surface
- N-Th Bolt size
- d- Bolt hole diameter

PN10 (GB/T9113.1)

DN	D	D1	D2	N-Th	d
50	165	125	99	4-M16	Φ18
65	185	145	118	4-M16	Φ18
80	200	160	132	8-M16	Φ18
100	220	180	156	8-M16	Φ18
125	250	210	184	8-M16	Φ18
150	285	240	211	8-M20	Φ23
200	340	295	266	8-M20	Φ23
250	395	350	319	12-M20	Φ23
300	445	400	370	12-M20	Φ23
350	505	460	429	16-M20	Φ23
400	565	515	480	16-M24	Φ27
450	615	565	530	20-M24	Φ27
500	670	620	582	20-M24	Φ27
600	780	725	682	20-M27	Φ30
700	895	840	794	24-M27	Φ30
800	1015	950	901	24-M30	Φ33
900	1115	1050	1001	28-M30	Φ33
1000	1230	1160	1112	28-M33	Φ36
1200	1455	1380	1328	32-M36	Φ39

PN16 (GB/T9113.1)

DN	D	D1	D2	N-Th	d
50	165	125	99	4-M16	Φ18
65	185	145	118	4-M16	Φ18
80	200	160	132	8-M16	Φ18
100	220	180	156	8-M16	Φ18
125	250	210	184	8-M16	Φ18
150	285	240	211	8-M20	Φ23
200	340	295	266	12-M20	Φ23
250	405	355	319	12-M24	Φ27
300	460	410	370	12-M24	Φ27
350	520	470	429	16-M24	Φ27
400	580	525	480	16-M27	Φ30
450	640	585	548	20-M27	Φ30
500	715	650	609	20-M30	Φ33
600	840	770	720	20-M33	Φ36
700	910	840	794	24-M33	Φ36
800	1025	950	901	24-M36	Φ39
900	1125	1050	1001	28-M36	Φ39
1000	1255	1170	1112	28-M39	Φ42
1200	1485	1390	1328	32-M45	Φ48

Flange and connection details

GB/T9113.1 PN10

DN	D1	n°	M	T	●	⊕	+
50	125	4	M-16	10	2--0		-2
65	145	4	M-16	10	2--0		-2
80	160	8	M-16	12	2--4		-2
100	180	8	M-16	12	2--4		-2
125	210	8	M-16	14	2--4		-2
150	240	8	M-20	14	2--4		-2
200	295	8	M-20	14	2--4		-2
250	350	12	M-20	18	4--6		-2
300	400	12	M-20	21	4--6		-2
350	460	16	M-20	21	6--8		-2
400	515	16	M-24	25	6--8		-2
450	565	20	M-24	25	8--10		-2
500	620	20	M-24	26	8--10		-2
600	725	20	M-27	26	8--10		-2
700	840	24	M-27	22	10--12		-2
800	950	24	M-30	22	10--12		-2
900	1050	28	M-30	22	12--12		-4
1000	1160	28	M-33	22	12--12		-4
1200	1380	32	M-36	33	14--14		-4

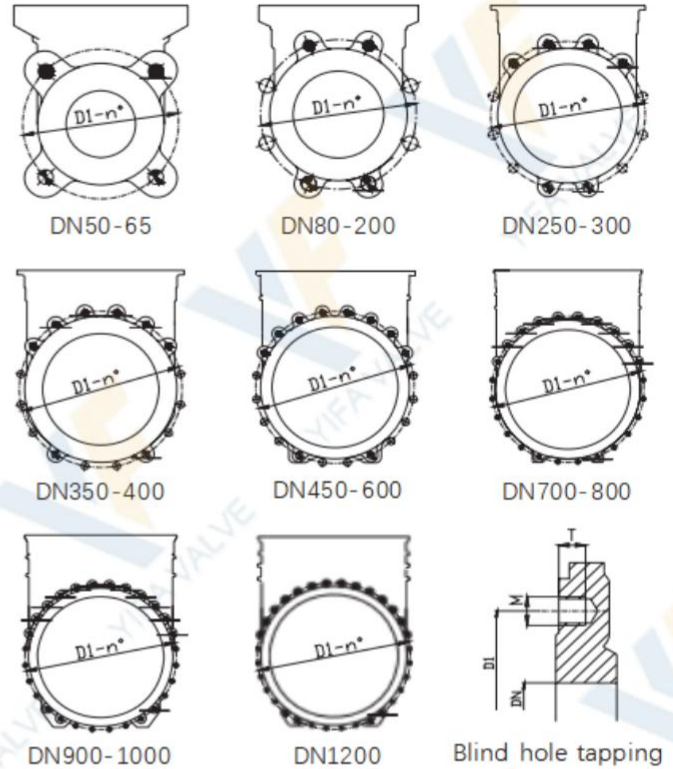

- Blind hole thread
- ⊕ Through hole
- Drilling through

GB/T9113.1 PN16

DN	D1	n°	M	T	●	⊕	+
50	125	4	M-16	10	2--0		-2
65	145	4	M-16	10	2--0		-2
80	160	8	M-16	12	2--4		-2
100	180	8	M-16	12	2--4		-2
125	210	8	M-16	14	2--4		-2
150	240	8	M-20	14	2--4		-2
200	295	12	M-20	14	2--4		-2
250	355	12	M-24	18	4--6		-2
300	410	12	M-24	21	4--6		-2
350	470	16	M-24	21	6--8		-2
400	525	16	M-27	25	6--8		-2
450	585	20	M-27	25	8--10		-2
500	640	20	M-30	26	8--10		-2
600	725	20	M-33	26	8--10		-2
700	840	24	M-33	22	10--12		-2
800	950	24	M-36	22	10--12		-2
900	1050	28	M-36	22	12--12		-4
1000	1170	28	M-39	22	12--12		-4
1200	1390	32	M-45	33	14--14		-4

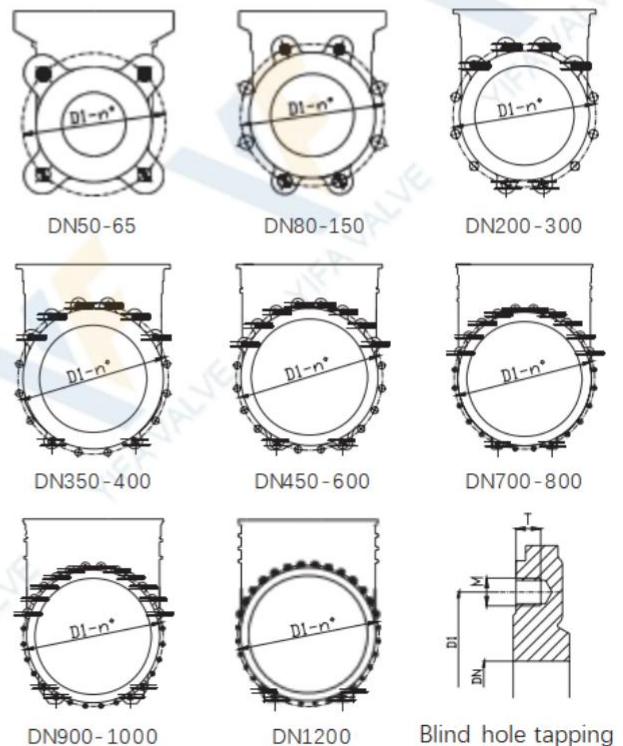

Blind hole tapping

Flange connection dimensions

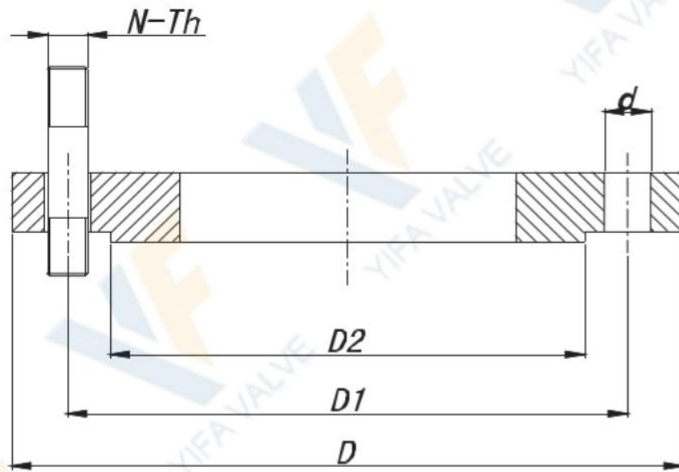

- D- Flange outer diameter
- D1- Bolt circle diameter
- D2- Diameter of sealing surface
- N-Th Bolt size
- d- Bolt hole diameter

10K (JIS B2239-2004)

150Lb (ANSI B16.5 & ASME B16.47)

DN	D	D1	D2	N-Th	d
50	155	120	96	4-M16	Φ19
65	175	140	116	4-M16	Φ19
80	185	150	126	8-M16	Φ19
100	210	175	151	8-M16	Φ19
125	250	210	182	8-M20	Φ23
150	280	240	212	8-M20	Φ23
200	330	290	262	12-M20	Φ23
250	400	355	324	12-M22	Φ25
300	445	400	368	16-M22	Φ25
350	490	445	413	16-M22	Φ25
400	560	510	475	16-M24	Φ27
450	620	565	530	20-M24	Φ27
500	675	620	585	20-M24	Φ27
550	745	680	640	20-M30	Φ33
600	795	730	690	24-M30	Φ33
650	845	780	740	24-M30	Φ33
700	905	840	800	24-M30	Φ33
750	970	900	855	24-M30	Φ33
800	1020	950	905	28-M30	Φ33
850	1070	1000	955	28-M30	Φ33
900	1120	1050	1005	28-M30	Φ33
1000	1235	1160	1110	28-M36	Φ39
1100	1345	1270	1220	28-M36	Φ39
1200	1465	1380	1325	32-M36	Φ39
1350	1630	1540	1480	36-M42	Φ45
1500	1795	1700	1635	40-M42	Φ45

DN	D	D1	D2	N-Th	d
2D	153	120.5	92	4-5/8DUNC	Φ19
2.5D	178	139.5	105	4-5/8DUNC	Φ19
3D	191	152.5	127	4-5/8DUNC	Φ19
4D	229	190.5	157	8-5/8DUNC	Φ19
5D	254	216	186	8-3/4DUNC	Φ22
6D	280	241.5	216	8-3/4DUNC	Φ22
8D	343	298.5	270	8-3/4DUNC	Φ22
10D	407	362	324	12-7/8DUNC	Φ25
12D	483	432	381	12-7/8DUNC	Φ25
14D	534	476	413	12-1DUNC	Φ29
16D	597	539.5	470	16-1DUNC	Φ29
18D	635	578	534	16-1 1/8DUNC	Φ32
20D	699	635	584	20-1 1/8DUNC	Φ32
24D	813	749.5	692	20-1 1/4DUNC	Φ35
26D	870	806.5	749	24-1 1/4DUNC	Φ35
28D	925	863.5	800	28-1 1/4DUNC	Φ35
30D	985	914.5	857	28-1 1/4DUNC	Φ35
32D	1060	978	914	28-1 1/2DUNC	Φ41
36D	1170	1086	1022	32-1 1/2DUNC	Φ41
40D	1290	1200	1124	36-1 1/2DUNC	Φ41
42D	1345	1257	1194	36-1 1/2DUNC	Φ41
44D	1405	1314	1245	40-1 1/2DUNC	Φ41
48D	1510	1422	1359	44-1 1/2DUNC	Φ41
52D	1625	1537	1461	44-1 3/4DUNC	Φ47
56D	1745	1651	1575	48-1 3/4DUNC	Φ47
60D	1855	1759	1676	52-1 3/4DUNC	Φ47

Flange and connection details

JIS B2239-2004 10K

DN	D1	n°	M	T	●	⊕	+
50	120	4	M-16	10	2--0		-2
65	140	4	M-16	10	2--0		-2
80	150	8	M-16	12	2--4		-2
100	175	8	M-16	12	2--4		-2
125	210	8	M-20	14	2--4		-2
150	240	8	M-20	14	2--4		-2
200	290	12	M-20	14	2--4		-2
250	355	12	M-22	18	4--6		-2
300	400	16	M-22	21	4--6		-2
350	445	16	M-22	21	6--8		-2
400	510	16	M-24	25	6--8		-2
450	565	20	M-24	25	8--10		-2
500	620	20	M-24	26	8--10		-2
600	730	24	M-30	26	8--10		-2
700	840	24	M-30	22	10--12		-2
800	950	28	M-30	22	10--12		-2
900	1050	28	M-30	22	12--12		-4
1000	1160	28	M-30	22	12--12		-4
1200	1380	32	M-36	33	14--14		-4



DN50-65



DN80-150

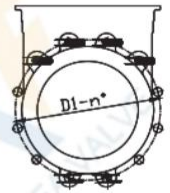

DN200-250



DN300-400



DN450-500

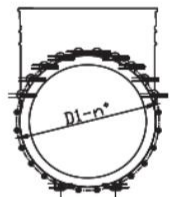

DN600-700



DN800-1000

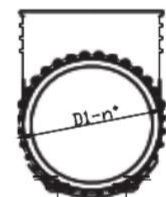

DN1200

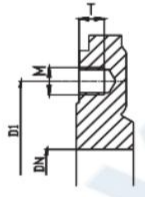

Blind hole tapping

- Blind hole thread
- ⊕ Through hole
- ⦿ Drilling through

ANSI B16.5 & ASME B16.47 150Lb

DN	D1	n°	M	T	●	⊕	+
2"	120.5	4	5/8" UNC	10	2--0		-2
2 1/2"	139.5	4	5/8" UNC	10	2--0		-2
3"	152.5	4	5/8" UNC	12	2--4		-2
4"	190.5	8	5/8" UNC	12	2--4		-2
5"	216	8	3/4" UNC	14	2--4		-2
6"	241.5	8	3/4" UNC	14	2--4		-2
8"	298.5	8	3/4" UNC	14	2--4		-2
10"	362	12	7/8" UNC	18	4--6		-2
12"	432	12	7/8" UNC	21	4--6		-2
14"	476	12	1" UNC	21	6--8		-2
16"	540	16	1" UNC	25	6--8		-2
18"	578	16	1 1/8" UNC	25	8--10		-2
20"	635	20	1 1/8" UNC	26	8--10		-2
24"	749.5	20	1 1/4" UNC	26	8--10		-2
28"	863.5	28	1 1/4" UNC	26	10--12		-2
30"	914	28	1 1/4" UNC	22	10--12		-2
32"	978	28	1 1/2" UNC	22	12--12		-4
36"	1085.8	32	1 1/2" UNC	22	12--12		-4
40"	1200.2	36	1 1/2" UNC	30	14--14		-4

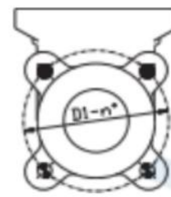

2"-3"



4"-8"

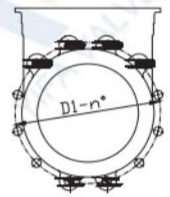

10"-14"

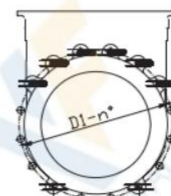

16"-18"

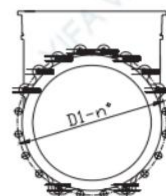

20"-24"

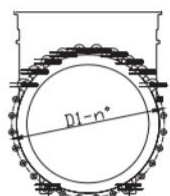

28"-32"

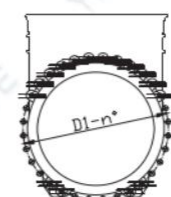

36"

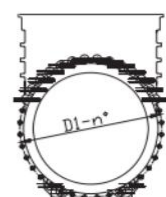

40"

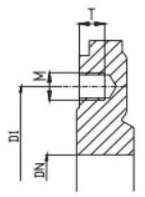

Blind hole tapping



ADDRESS

No.2 Road, Jinnan District
Industrial Zone, Xiaozhan
Town, Jinnan District, Tianjin,
China



PHONE

0086 0379 69926196



EMAIL

valve@yifavalves.com