



# YFH77X WAFER CHECK VALVE

## Product Description

YFH77X Dual-Plate Wafer Check Valve is a compact, lightweight non-return valve designed for efficient flow control and reliable backflow prevention in pipeline systems.

With its short face-to-face length and wafer-type structure, the valve offers excellent space-saving advantages, making it ideal for installations where space is limited. Its optimized internal design ensures superior hydrodynamic performance, resulting in minimal pressure loss and improved system efficiency.

The valve operates automatically: when fluid flows through the pipeline, the pressure pushes the dual plates open against the spring force. Once the flow stops or reverses, the spring quickly returns the plates to the closed position, ensuring fast response and effective sealing to prevent backflow.



### Technical Data

Size range	DN50-DN800
Pressure range	PN 10-16/Class 150/JIS10K
Temperature	EPDM : -10°C to +100 °C NBR: - 10°C to + 80 °C VITON :-10°C to + 180°C
Design	GB/T 12224
Face to face	JB/T 8937
Connection	JB/T 79.1
Coating	Electrostatic Powder Epoxy/Spray
Testing	JB/T 9092
Medium	Water,oil,Gas

### Application Range

- HVAC Systems
- Pumping Stations
- Water Treatment Plants
- Reservoirs and Tanks
- Irrigation
- Industrial Applications

### Related Products

- YFZ44T MATEL SEAT GATE VALVE
- YFPZ73X KNIFE GATE VALVE
- YFH44X SWING CHECK VALVE



HVAC



IRRIGATION



POTABLE WATER



INDUSTRY

# YFH77X

## WAFER CHECK VALVE

### Product Description

---

#### 1. Compact & Lightweight Design

Short face-to-face length, compact structure and light weight for easy installation, handling and maintenance.

#### 2. Spring-Assisted Fast-Closing Dual Plate

Dual-disc design paired with spring torque enables rapid closing for instant response to flow reversal.

#### 3. Backflow Prevention & Water Hammer Mitigation

Fast closure minimizes reverse flow and significantly reduces water hammer, protecting pipelines and equipment.

#### 4. High Structural Strength & Reliability

Rigid, durable valve body ensures safe and stable operation under diverse working conditions.

#### 5. Precision-Sealed Performance

CNC-machined sealing surface with high flatness and low roughness, plus optimized design for tight sealing and zero leakage under proper conditions.

#### 6. Durable Corrosion Protection

Vulcanized rubber seat (bonding strength >1.7 MPa) prevents detachment; high-quality epoxy powder coating offers long-lasting corrosion resistance for indoor/outdoor use.

#### 7. Low Pressure Loss & Wide Application

Streamlined internal design reduces flow resistance to boost system efficiency; suitable for water supply, drainage, HVAC and general industrial pipelines.



# YFH77X

## WAFER CHECK VALVE

Worm Gear DN50-DN350

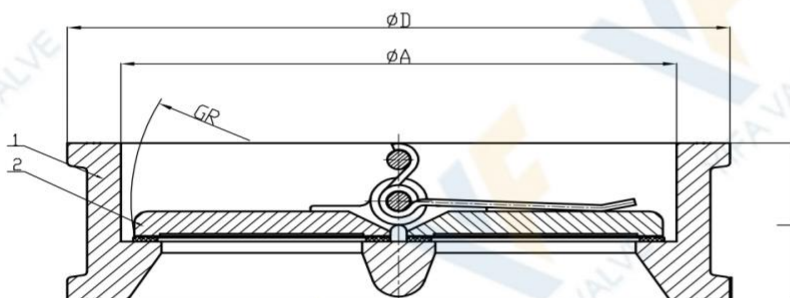

### Technical Data

Test Pressure

Nominal pressure PN16

Shell test pressure 24bar

Sealing test pressure 17.6bar

NO.	Name	Qty	Material
1	Body+Seat	1	CI/DI/WCB/SS304
2	Disc	2	DI/SS304/SS316
3	Stem	2	SS410
4	Spring	2	SS304
5	Washers	3	F4
6	Disc Washers	2	F4
7	Seat	4	EPDM/NBR/PTFE
8	Hexagon socket set screws	4	Carbon Steel
9	Nameplate	1	H62
10	Rivet	2	ML2
11	Eyebolt	1	Carbon Steel (DN200-DN700)

SIZE	L	ØA	PN10	PN16	PN25	CL150	10K	BS10 D	BS10 E	GR
			ØD							
DN50	43	65	107	107	107	103	101	107	107	28.8
			127	127	127		121	127	127	36.1
DN80	64	94	142	142	142	133	131	142	142	43.4
DN125	70	145	192	192	192	192	187	192	192	65.7
DN200	89	224	273	273	282	276	267	270	270	104.4
DN300	114	310	378	382	399	406	375	380	380	148.3
DN400	140	410	487	494	513	511	483	492	492	197.4
DN450	152	450	537	554	563	546	538	554	554	217.8
DN500	152	505	592	616	623	603	593	615	615	241
DN600	178	624	694	733	730	714	697	725	723	295.4
DN700	229	720	809	803	851	827	806	815	812	354

# YFH77X WAFER CHECK VALVE



## Installation

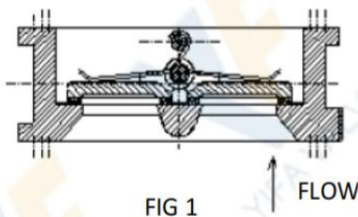

FIG 1  
RECOMMENDED  
INSTALLATION POSITION

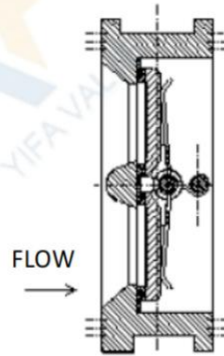

FIG 2  
RECOMMENDED INSTALLATION  
POSITION

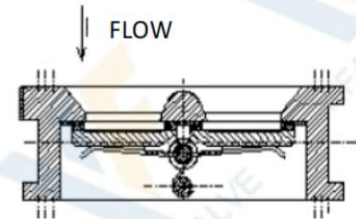

FIG 3  
NOT RECOMMENDED  
INSTALLATION POSITION

NOTE: VALVE MUST BE INSTALLED WITH  
SHAFT IN VERTICAL POSITION IN A  
HORIZONTAL PIPE. THIS VIEW  
ROTATED 90° FOR PICTORIAL  
CLARITY.

### CAUTION

During freight seal two ends to make sure no material enters the valve Before Installaton:

- 1: Check the valve is suitable for working conditons
- 2: Clean the seat surface
- 3: Clean any material or impurity from the pipeline
- 4: Valve is to be installed a minimum of 8-10 pipe diameters from the pump (failure to do so may damage valve and will void warranty)

Installaton should comply with the above recommended positon

- 1: Make sure all bolts fastened to the valve have the same force
- 2: The valve is only suitable for single fow directon
- 3: A minimum back pressure is required to seal the valve. Varies based on applicaton

### Pressure drops

DN	Kv	Cv
50	167	160
65	290	275
80	380	365
100	650	620
125	1165	1115
150	1520	1450
200	2835	2710
250	4485	4285
300	5675	5420
350	7130	6810
400	9220	8805
450	11465	10950
500	14940	14270
600	21875	20895

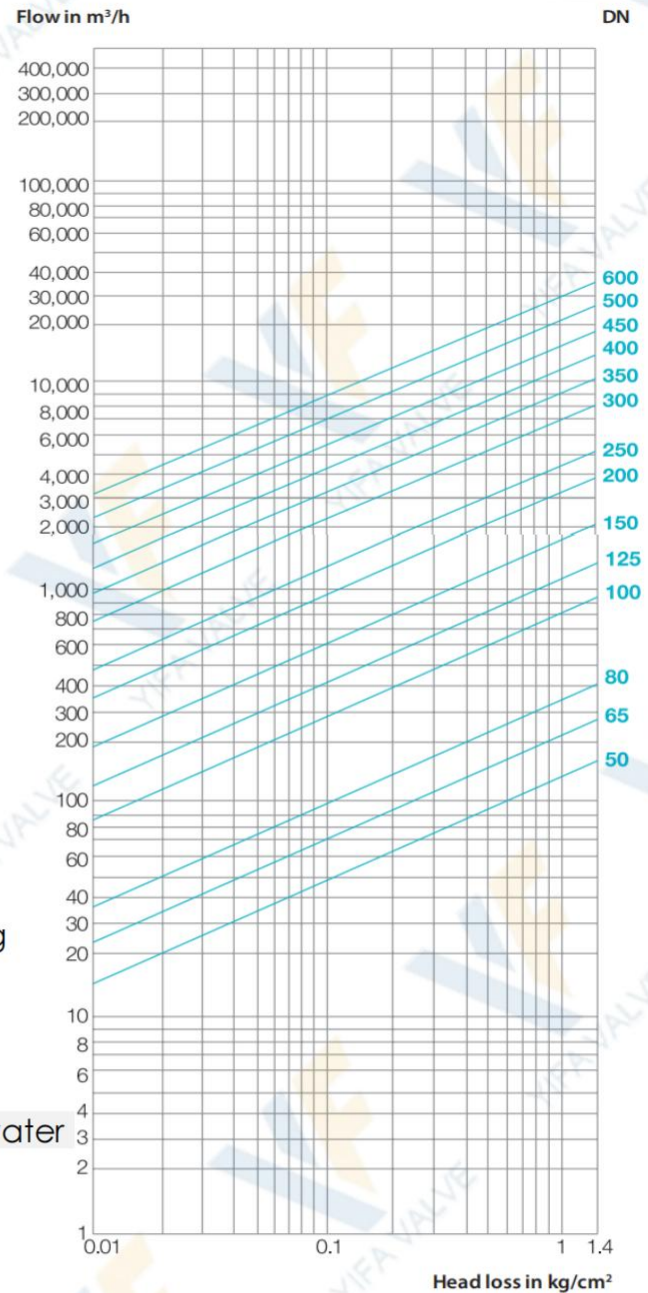

$$Kv = Q \sqrt{\frac{d'}{\Delta P}}$$

$$\Delta P = \left( \frac{Q}{Kv} \right)^2 d$$

Kv: flow coefficient. Flow of water in m<sup>3</sup>/h passing through the valve and generating a pressure drop of 1 bar.

Q: flow in m<sup>3</sup>/h

Δ P: pressure drop in bar

d: relative density of the fluid (1 in the case of water at 4°C)

$$Cv = Q \sqrt{\frac{d}{\Delta P}}$$

$$\Delta P = \left( \frac{Q}{Cv} \right)^2 d$$

Cv: gallons per minute that pass through the valve for the pressure drop to be 1 psi.

Q: flow in gallons/min

Δ P: pressure drop in psi

d: relative density of the fluid (1 in the case of water at 60°F)

### Cv Value

Wafer Check Valve Flow Coefficient Cv Value (in<sup>2</sup>)

SIZE		Valve opening angle								
DN	NPS	10°	20°	30°	40°	50°	60°	70°	80°	90°
50	2	0.06	3	7	15	27	44	70	105	115
65	2½	0.1	6	12	25	45	75	119	178	196
80	3	0.2	9	18	39	70	116	183	275	302
100	4	0.3	17	36	78	139	230	364	546	600
125	5	0.5	29	61	133	237	392	620	930	1022
150	6	0.8	34	95	153	257	422	706	1154	1579
200	8	2	56	154	251	422	693	1158	1892	2165
250	10	3	87	238	385	654	1073	1794	2931	3353
300	12	4	153	417	681	1145	1879	3142	5132	5827
350	14	6	183	500	816	1372	2252	3765	6150	7037
400	16	8	271	740	1208	2031	3333	5573	9104	10416
450	18	11	318	867	1417	2382	3909	6535	10676	12215
500	20	14	415	1133	1851	3112	5107	8538	13948	15959
600	24	22	541	1482	2421	4069	6678	11165	18240	20869
700	28	36	1813	3639	6636	10000	19449	22768	34898	49500
750	30	37	2080	4406	9546	17010	28147	44545	66818	73426
800	32	45	2387	4791	8736	13788	20613	31395	48117	38250

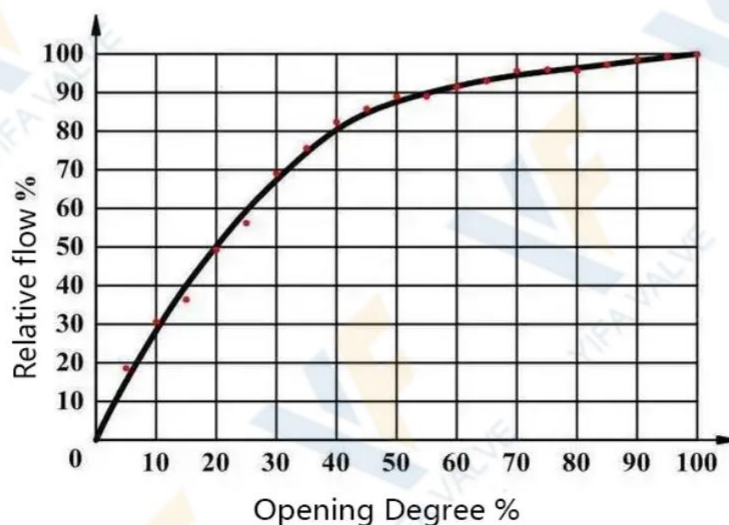

## Seal parts

Parts	Characteristic	Low/High Temperature		Recommended
NR	High elasticity	-20	85	-5~70
NBR	Oil resistivity	-30	100	-15~90
EPDM	Aging resistance, ozone resistance, corrosion resistance	-40	125	-25~110
HT EPDM	Same as above, added heat resistance	-40	150	-25~135
SBR (wear-resistant)	Excellent traction performance and wear resistance	-30	100	-15~80
CR (neoprene)	Oil, heat, flame, sunlight, ozone, acid and alkali resistance	-30	125	-15~100
Hypalon	Oxidation resistance, resistance to winding and cracking	-40	120	-25~110
FPM (viton)	Chemical and most oils resistance, (except ketones & esters)	-20	200	-5~150
MVQ (silicon)	High and low temperature resistance, oil, corrosion resistance	-55	200	-30~180
PU	Chemical, oil, wear, low temperature, aging resistance	-20	120	-5~90
FEP (F46)	Chemical resistance, radiation resistance	-20	150	-5~120
PTFE	Heat, cold, acid, alkali, organic solvents resistant	-60	180	-45~150
RPTFE	Corrosion resistance, low friction coefficient	-60	180	-45~150
PFA	Excellent chemical corrosion resistance, low friction coefficient	-196	200	-60~180
PPL	High temperature and chemical corrosion resistance	-60	230	-45~200
UPVC	Corrosion and pressure resistance, hygiene	-30	100	-15~80
CPVC	Corrosion and pressure resistance, hygiene	-30	110	-15~95
PVDF	Anti aging and chemical resistance	-30	100	-15~70
PEEK	High temperature and chemical resistance	-60	300	-45~260
Flexible graphite	Cold and hot resistant, corrosion resistant, self-lubricating	-200	600	-60~550
Ceramic fiber	Fire, high temperature resistance, low thermal conductivity	-200	1050	-60~950
Metal to metal	High temperature, high pressure, wear, corrosion resistance	Refer to the material		

Unit: Degree $\ddot{y}$

## Inspection Standards and Requirements

Inspection Standards and Requirements							
		ISO5208:2008 / GB/T13927			API598-2004		
Shell strength	Medium temperature	5~40			5~40		
	Medium	Water, kerosene, air, suitable gas			Water, kerosene, air, suitable gas		
	Test pressure	Norminal pressure (PN)×1.5			Norminal pressure×1.5		
	Minimum duration of the test	DN	Seconds		NPS	Check valve	Others
		≤50	15		≤2"	60	15
		65~200	60		2½"~6"	60	60
≥250		180		8"~12"	60	120	
Assessment	No visible leakage allowed			No visible leakage allowed			
Back seal	Test pressure	DN	PN	Pressure	NPS	Class	Pressure
		≤80	All	0.6Mpa	All	≤300	0.4~0.7Mpa
		100~200	≤5.0	0.6Mpa			
		100~200	>5.0	PN × 1.1		>300	Class x 1.1
	≥250	All	PN × 1.1				
Assessment	No visible leakage allowed			No visible leakage allowed			
High pressure sealing test	Test pressure	DN	PN	Pressure	Class	Ductile iron	Steel
		≤80	All	PN × 1.1 (liquid)	150	1.7 Mpa	Class x 1.1
		100~200	≤5.0	0.5~0.7Mpa (air)			
		100~200	>5.0	PN × 1.1 (liquid)	300	4.4 Mpa	
		≥250	All	0.5~0.7Mpa (air)			
		100~200	>5.0	PN × 1.1 (liquid)	300	4.4 Mpa	
	≥250	All	PN × 1.1 (liquid)				
	Minimum duration of the test	DN	Metal seal	Resilient seal	NPS	Check valve	Others
		≤50	15	15	≤2"	60	15
		65~200	30	15	2½"~6"	60	60
		250~450	60	30	8"~12"	60	120
		≥500	120	60	≥14"	120	120
	Assessment	Class (level)	Liquid leakage	Air leakage	NPS	Liquid & Air	Liquid & Air
		A	No visible leakage allowed (mm <sup>3</sup> /s)		≤2"	Liquid:3cm <sup>3</sup> /in. min Air:0.042m <sup>3</sup> /in.h	0 drop(bubble)/min
		B	DN x 0.01	DN x 0.3	2½"~6"		12 & 24
		C	DN x 0.03	DN x 3	8"~12"	20 & 40	
D	DN x 0.1	DN x 30	≥14"	2 & 4 / in ·min			
Low pressure sealing test	Medium	Air, suitable gas			Air, suitable gas		
	Test pressure	0.5~0.7 Mpa			0.4~0.7 Mpa		
		DN	Metal seal	Resilient seal	NPS	Check valve	Others
		≤50	15	15	≤2"	60	15
	Minimum duration of the test	65~200	30	15	2½"~6"	60	60
		250~450	60	30	8"~12"	60	120
		≥500	120	60	≥14"	120	120
	Assessment	Class (level)	Air leakage		NPS	Air leakage	
		A	No visible leakage allowed (mm <sup>3</sup> /s)		≤2"	0 bubble /min	
		B	DN x 0.3		2½"~6"	0.042 m <sup>3</sup> /in ·h	24
C		DN x 3		8"~12"	40		
D		DN x 30		≥14"	4 / in ·min		

## Flange connection dimensions

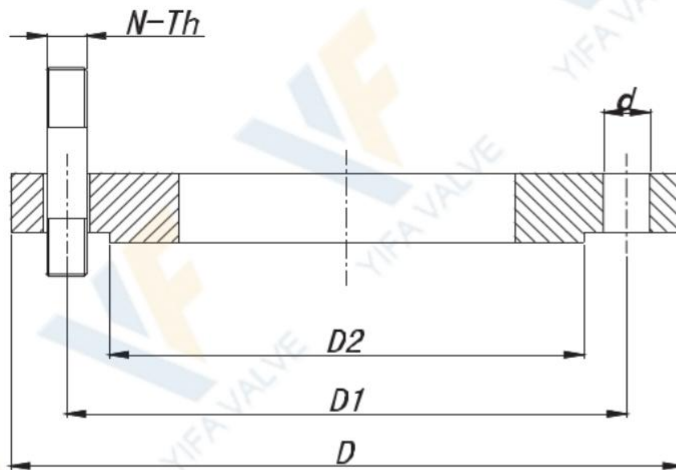

- D- Flange outer diameter
- D1- Bolt circle diameter
- D2- Diameter of sealing surface
- N-Th Bolt size
- d- Bolt hole diameter

### PN10 (DIN2632)

DN	D	D1	D2	N-Th	d
DN	D	D1	D2	N-Th	d
50	165	125	102	4-M16	Φ18
65	185	145	122	4-M16	Φ18
80	200	160	138	8-M16	Φ18
100	220	180	158	8-M16	Φ18
125	250	210	188	8-M16	Φ18
150	285	240	212	8-M20	Φ23
200	340	295	268	12-M20	Φ23
250	405	355	320	12-M24	Φ27
300	460	410	378	12-M24	Φ27
350	520	470	438	16-M24	Φ27
400	580	525	490	16-M27	Φ30
450	640	585	550	20-M27	Φ30
500	715	650	610	20-M30	Φ33
600	840	770	725	20-M33	Φ36
700	910	840	795	24-M33	Φ36
800	1025	950	900	24-M36	Φ39
900	1125	1050	1000	28-M36	Φ39
1000	1255	1170	1115	28-M39	Φ42
1200	1485	1390	1330	32-M45	Φ48
1400	1685	1590	1530	36-M45	Φ48
1600	1930	1820	1750	40-M52	Φ56
1800	2130	2020	1950	44-M52	Φ56
2000	2345	2230	2150	48-M56	Φ62

### PN16 (DIN2632)

DN	D	D1	D2	N-Th	d
DN	D	D1	D2	N-Th	d
50	165	125	102	4-M16	Φ18
65	185	145	122	4-M16	Φ18
80	200	160	138	8-M16	Φ18
100	220	180	158	8-M16	Φ18
125	250	210	188	8-M16	Φ18
150	285	240	212	8-M20	Φ23
200	340	295	268	12-M20	Φ23
250	405	355	320	12-M24	Φ27
300	460	410	378	12-M24	Φ27
350	520	470	438	16-M24	Φ27
400	580	525	490	16-M27	Φ30
450	640	585	550	20-M27	Φ30
500	715	650	610	20-M30	Φ33
600	840	770	725	20-M33	Φ36
700	910	840	795	24-M33	Φ36
800	1025	950	900	24-M36	Φ39
900	1125	1050	1000	28-M36	Φ39
1000	1255	1170	1115	28-M39	Φ42
1200	1485	1390	1330	32-M45	Φ48
1400	1685	1590	1530	36-M45	Φ48
1600	1930	1820	1750	40-M52	Φ56
1800	2130	2020	1950	44-M52	Φ56
2000	2345	2230	2150	48-M56	Φ62

## Flange connection dimensions

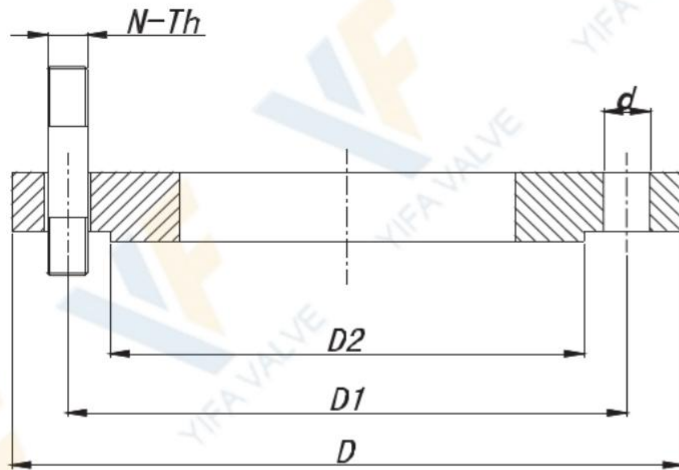

- D- Flange outer diameter
- D1- Bolt circle diameter
- D2- Diameter of sealing surface
- N-Th Bolt size
- d- Bolt hole diameter

PN10 (GB/T9113.1)

DN	D	D1	D2	N-Th	d
50	165	125	99	4-M16	Φ18
65	185	145	118	4-M16	Φ18
80	200	160	132	8-M16	Φ18
100	220	180	156	8-M16	Φ18
125	250	210	184	8-M16	Φ18
150	285	240	211	8-M20	Φ23
200	340	295	266	8-M20	Φ23
250	395	350	319	12-M20	Φ23
300	445	400	370	12-M20	Φ23
350	505	460	429	16-M20	Φ23
400	565	515	480	16-M24	Φ27
450	615	565	530	20-M24	Φ27
500	670	620	582	20-M24	Φ27
600	780	725	682	20-M27	Φ30
700	895	840	794	24-M27	Φ30
800	1015	950	901	24-M30	Φ33
900	1115	1050	1001	28-M30	Φ33
1000	1230	1160	1112	28-M33	Φ36
1200	1455	1380	1328	32-M36	Φ39

PN16 (GB/T9113.1)

DN	D	D1	D2	N-Th	d
50	165	125	99	4-M16	Φ18
65	185	145	118	4-M16	Φ18
80	200	160	132	8-M16	Φ18
100	220	180	156	8-M16	Φ18
125	250	210	184	8-M16	Φ18
150	285	240	211	8-M20	Φ23
200	340	295	266	12-M20	Φ23
250	405	355	319	12-M24	Φ27
300	460	410	370	12-M24	Φ27
350	520	470	429	16-M24	Φ27
400	580	525	480	16-M27	Φ30
450	640	585	548	20-M27	Φ30
500	715	650	609	20-M30	Φ33
600	840	770	720	20-M33	Φ36
700	910	840	794	24-M33	Φ36
800	1025	950	901	24-M36	Φ39
900	1125	1050	1001	28-M36	Φ39
1000	1255	1170	1112	28-M39	Φ42
1200	1485	1390	1328	32-M45	Φ48

## Flange and connection details

### GB/T9113.1 PN10

DN	D1	n°	M	T	●	⊕	+
50	125	4	M-16	10	2--0		-2
65	145	4	M-16	10	2--0		-2
80	160	8	M-16	12	2--4		-2
100	180	8	M-16	12	2--4		-2
125	210	8	M-16	14	2--4		-2
150	240	8	M-20	14	2--4		-2
200	295	8	M-20	14	2--4		-2
250	350	12	M-20	18	4--6		-2
300	400	12	M-20	21	4--6		-2
350	460	16	M-20	21	6--8		-2
400	515	16	M-24	25	6--8		-2
450	565	20	M-24	25	8--10		-2
500	620	20	M-24	26	8--10		-2
600	725	20	M-27	26	8--10		-2
700	840	24	M-27	22	10--12		-2
800	950	24	M-30	22	10--12		-2
900	1050	28	M-30	22	12--12		-4
1000	1160	28	M-33	22	12--12		-4
1200	1380	32	M-36	33	14--14		-4

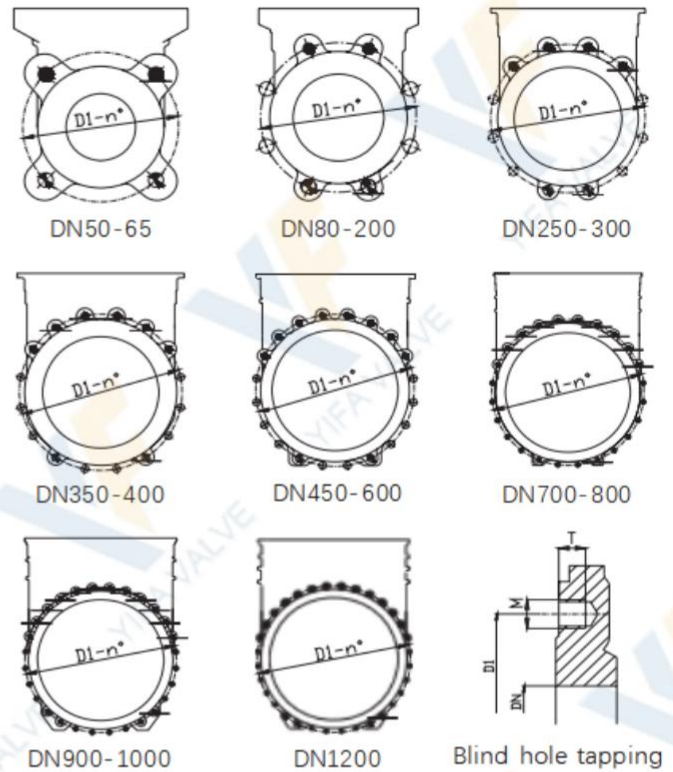

- Blind hole thread
- ⊕ Through hole
- Drilling through

### GB/T9113.1 PN16

DN	D1	n°	M	T	●	⊕	+
50	125	4	M-16	10	2--0		-2
65	145	4	M-16	10	2--0		-2
80	160	8	M-16	12	2--4		-2
100	180	8	M-16	12	2--4		-2
125	210	8	M-16	14	2--4		-2
150	240	8	M-20	14	2--4		-2
200	295	12	M-20	14	2--4		-2
250	355	12	M-24	18	4--6		-2
300	410	12	M-24	21	4--6		-2
350	470	16	M-24	21	6--8		-2
400	525	16	M-27	25	6--8		-2
450	585	20	M-27	25	8--10		-2
500	640	20	M-30	26	8--10		-2
600	725	20	M-33	26	8--10		-2
700	840	24	M-33	22	10--12		-2
800	950	24	M-36	22	10--12		-2
900	1050	28	M-36	22	12--12		-4
1000	1170	28	M-39	22	12--12		-4
1200	1390	32	M-45	33	14--14		-4

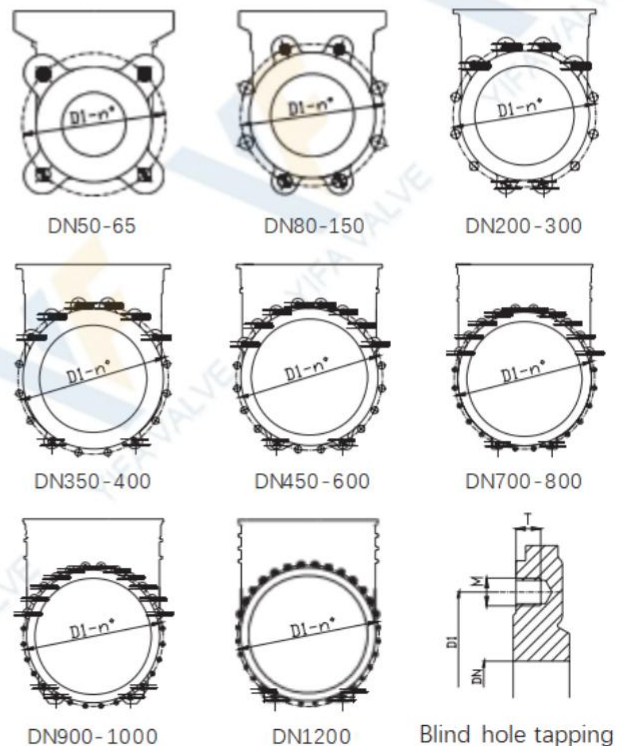

Blind hole tapping

## Flange connection dimensions

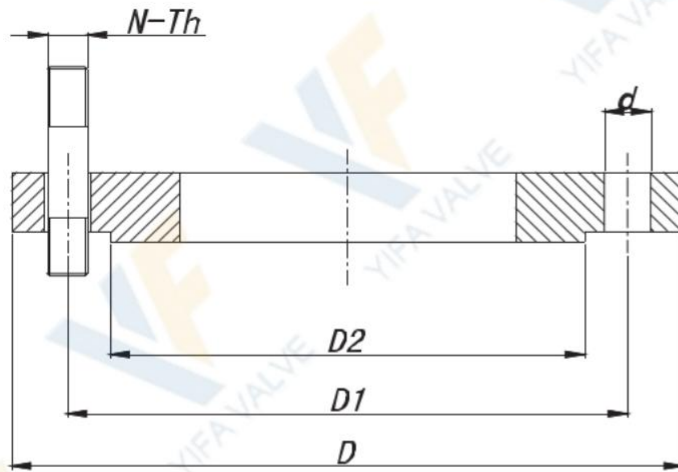

- D- Flange outer diameter
- D1- Bolt circle diameter
- D2- Diameter of sealing surface
- N-Th Bolt size
- d- Bolt hole diameter

10K (JIS B2239-2004)

150Lb (ANSI B16.5 & ASME B16.47)

DN	D	D1	D2	N-Th	d
50	155	120	96	4-M16	Φ19
65	175	140	116	4-M16	Φ19
80	185	150	126	8-M16	Φ19
100	210	175	151	8-M16	Φ19
125	250	210	182	8-M20	Φ23
150	280	240	212	8-M20	Φ23
200	330	290	262	12-M20	Φ23
250	400	355	324	12-M22	Φ25
300	445	400	368	16-M22	Φ25
350	490	445	413	16-M22	Φ25
400	560	510	475	16-M24	Φ27
450	620	565	530	20-M24	Φ27
500	675	620	585	20-M24	Φ27
550	745	680	640	20-M30	Φ33
600	795	730	690	24-M30	Φ33
650	845	780	740	24-M30	Φ33
700	905	840	800	24-M30	Φ33
750	970	900	855	24-M30	Φ33
800	1020	950	905	28-M30	Φ33
850	1070	1000	955	28-M30	Φ33
900	1120	1050	1005	28-M30	Φ33
1000	1235	1160	1110	28-M36	Φ39
1100	1345	1270	1220	28-M36	Φ39
1200	1465	1380	1325	32-M36	Φ39
1350	1630	1540	1480	36-M42	Φ45
1500	1795	1700	1635	40-M42	Φ45

DN	D	D1	D2	N-Th	d
2D	153	120.5	92	4-5/8DUNC	Φ19
2.5D	178	139.5	105	4-5/8DUNC	Φ19
3D	191	152.5	127	4-5/8DUNC	Φ19
4D	229	190.5	157	8-5/8DUNC	Φ19
5D	254	216	186	8-3/4DUNC	Φ22
6D	280	241.5	216	8-3/4DUNC	Φ22
8D	343	298.5	270	8-3/4DUNC	Φ22
10D	407	362	324	12-7/8DUNC	Φ25
12D	483	432	381	12-7/8DUNC	Φ25
14D	534	476	413	12-1DUNC	Φ29
16D	597	539.5	470	16-1DUNC	Φ29
18D	635	578	534	16-1 1/8DUNC	Φ32
20D	699	635	584	20-1 1/8DUNC	Φ32
24D	813	749.5	692	20-1 1/4DUNC	Φ35
26D	870	806.5	749	24-1 1/4DUNC	Φ35
28D	925	863.5	800	28-1 1/4DUNC	Φ35
30D	985	914.5	857	28-1 1/4DUNC	Φ35
32D	1060	978	914	28-1 1/2DUNC	Φ41
36D	1170	1086	1022	32-1 1/2DUNC	Φ41
40D	1290	1200	1124	36-1 1/2DUNC	Φ41
42D	1345	1257	1194	36-1 1/2DUNC	Φ41
44D	1405	1314	1245	40-1 1/2DUNC	Φ41
48D	1510	1422	1359	44-1 1/2DUNC	Φ41
52D	1625	1537	1461	44-1 3/4DUNC	Φ47
56D	1745	1651	1575	48-1 3/4DUNC	Φ47
60D	1855	1759	1676	52-1 3/4DUNC	Φ47

## Flange and connection details

### JIS B2239-2004 10K

DN	D1	n°	M	T	●	⊕	+
50	120	4	M-16	10	2--0		-2
65	140	4	M-16	10	2--0		-2
80	150	8	M-16	12	2--4		-2
100	175	8	M-16	12	2--4		-2
125	210	8	M-20	14	2--4		-2
150	240	8	M-20	14	2--4		-2
200	290	12	M-20	14	2--4		-2
250	355	12	M-22	18	4--6		-2
300	400	16	M-22	21	4--6		-2
350	445	16	M-22	21	6--8		-2
400	510	16	M-24	25	6--8		-2
450	565	20	M-24	25	8--10		-2
500	620	20	M-24	26	8--10		-2
600	730	24	M-30	26	8--10		-2
700	840	24	M-30	22	10--12		-2
800	950	28	M-30	22	10--12		-2
900	1050	28	M-30	22	12--12		-4
1000	1160	28	M-30	22	12--12		-4
1200	1380	32	M-36	33	14--14		-4

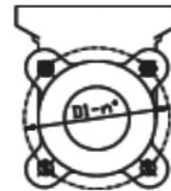

DN50-65



DN80-150

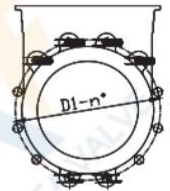

DN200-250



DN300-400



DN450-500

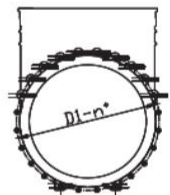

DN600-700

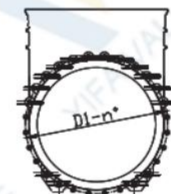

DN800-1000

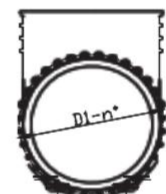

DN1200

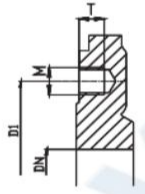

Blind hole tapping

- Blind hole thread
- ⊕ Through hole
- ⦿ Drilling through

### ANSI B16.5 & ASME B16.47 150Lb

DN	D1	n°	M	T	●	⊕	+
2"	120.5	4	5/8" UNC	10	2--0		-2
2 1/2"	139.5	4	5/8" UNC	10	2--0		-2
3"	152.5	4	5/8" UNC	12	2--4		-2
4"	190.5	8	5/8" UNC	12	2--4		-2
5"	216	8	3/4" UNC	14	2--4		-2
6"	241.5	8	3/4" UNC	14	2--4		-2
8"	298.5	8	3/4" UNC	14	2--4		-2
10"	362	12	7/8" UNC	18	4--6		-2
12"	432	12	7/8" UNC	21	4--6		-2
14"	476	12	1" UNC	21	6--8		-2
16"	540	16	1" UNC	25	6--8		-2
18"	578	16	1 1/8" UNC	25	8--10		-2
20"	635	20	1 1/8" UNC	26	8--10		-2
24"	749.5	20	1 1/4" UNC	26	8--10		-2
28"	863.5	28	1 1/4" UNC	26	10--12		-2
30"	914	28	1 1/4" UNC	22	10--12		-2
32"	978	28	1 1/2" UNC	22	12--12		-4
36"	1085.8	32	1 1/2" UNC	22	12--12		-4
40"	1200.2	36	1 1/2" UNC	30	14--14		-4

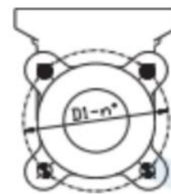

2"-3"



4"-8"

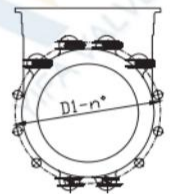

10"-14"

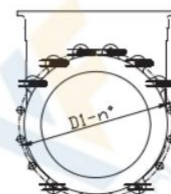

16"-18"



20"-24"

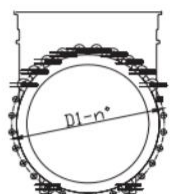

28"-32"

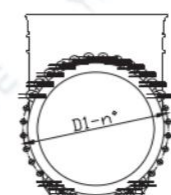

36"

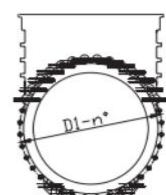

40"

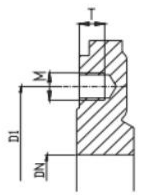

Blind hole tapping



#### ADDRESS

No.2 Road, Jinnan District  
Industrial Zone, Xiaozhan  
Town, Jinnan District, Tianjin,  
China



#### PHONE

0086 0379 69926196



#### EMAIL

[valve@yifavalves.com](mailto:valve@yifavalves.com)