

YFJ41T

GLOBE VALVE

Product Description

YFJ41T globe valve is designed for precise flow control, reliable sealing, and durable performance in pipeline systems.

With a precision-cast body, wear-resistant stainless steel seat, and optimized internal structure, the valve provides excellent throttling capability and tight shut-off performance.

It is Made of premium-grade cast iron (GG25/GGG50) for excellent corrosion resistance and mechanical strength. Robust design with a full-port or reduced-port structure to suit diverse flow requirements.



Technical Data

Size range	DN15-DN300
Pressure range	PN 10-16/Class 150/JIS10K
Temperature	- 10°C to 200 °C
Design	DIN3356, ASME B 16.34, JIS B2071
Face to face	DIN3202 F1, ANSI B16.1, JIS2002
Connection	BS EN1092-2 PN16, ANSI B16.1, JIS2212/2213
Coating	Electrostatic Powder Epoxy/Spray
Testing	API598
Medium	Water, oil, Gas

Application Range

- HVAC Systems
- Pumping Stations
- Water Treatment Plants
- Reservoirs and Tanks
- Irrigation
- Industrial Applications

Related Products

- YFZ44T METAL SEAT GATE VALVE
- YFPZ73X KNIFE GATE VALVE
- YFH44X SWING CHECK VALVE



HVAC



IRRIGATION



POTABLE WATER



INDUSTRY

YFJ41T

GLOBE VALVE

Product Description

1. **Premium Cast Body & Robust Construction**

Precision-cast, defect-free body with a heavy-duty structure ensures long-term reliability and strength under continuous operation.

2. **Excellent Flow Regulation & Control**

The globe valve design delivers precise throttling and flow control, ideal for applications requiring accurate regulation.

3. **Wear & Corrosion Resistant Seating**

The seat is available in 13% Cr stainless steel or brass, offering superior resistance to wear, erosion, and corrosion for extended service life.

4. **Leak-Proof & Safe Sealing System**

Features an inverted backseat design and optimized sealing structure, ensuring tight shut-off, preventing external leakage, and enhancing operational safety.

5. **High-Precision Machined Components**

All internal parts (including the cyclone-milled stem) are CNC-machined for accurate dimensions, straightness, and smooth, consistent operation.

6. **Rigorous Quality & Surface Treatment**

Double shot blasting for a high-quality finish, plus 100% shell and seat pressure testing, guaranteeing each valve meets standards and performs reliably.



YFJ41T GLOBE VALVE

DIN3202-F1 PN16 DN-DN300

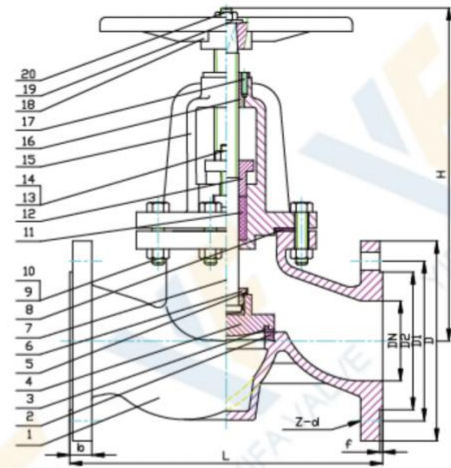

NO	PART NAME	MATERIAL
1	BODY	GG25/GGG50
2	BODY SEAT RING	BRASS/SS304
3	DISC SEAT RING	BRASS/SS304
4	DISC	DUCTILE TRON
5	COPPER WASHER	BRASS
6	DISC NUT	BRASS
7	STEM	2Cr13
8	GASKET	NBR
9	BDNNET BOLT	CARBON STEEL
10	NUT	CARBON STEEL
11	PACKING	GRAPHITE
12	GLAND	DUCTILE IRON

Inspection Specification

PN	16
Seat test	1.76 Mpa
Shell test	2.4 Mpa
Temp:	-10-200°C
Medium	Water, Oil, Gas

DN	D	D1	D2	L	b	f	Z-d	H
Ø15	Ø95	Ø65	Ø46	130	14	2	4-Ø14	215
Ø20	Ø105	Ø75	Ø56	150	16	2	4-Ø14	220
Ø25	Ø115	Ø85	Ø65	160	16	3	4-Ø14	230
Ø32	Ø140	Ø100	Ø76	180	18	3	4-Ø18	249
Ø40	Ø150	Ø110	Ø84	200	18	3	4-Ø18	258
Ø50	Ø165	Ø125	Ø99	230	20	3	4-Ø18	276
Ø65	Ø185	Ø145	Ø118	290	20	3	4-Ø18	302
Ø80	Ø200	Ø160	Ø132	310	22	3	8-Ø18	322
Ø100	Ø220	Ø180	Ø156	350	24	3	8-Ø18	347
Ø125	Ø250	Ø210	Ø184	400	26	3	8-Ø18	406
Ø150	Ø285	Ø240	Ø211	480	26	3	8-Ø22	433
Ø200	Ø340	Ø295	Ø266	600	30	3	12-Ø22	506
Ø250	Ø405	Ø355	Ø319	730	32	3	12-Ø26	556
Ø300	Ø460	Ø410	Ø370	850	32	4	12-Ø26	648

YFJ41T GLOBE VALVE

BS5152 PN16 DN15-DN300

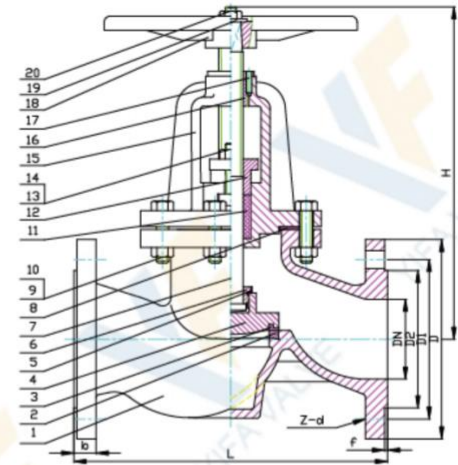

Inspection Specification

PN	16
Seat test	1.76 Mpa
Shell test	2.4 Mpa
Temp:	-10-200°C
Medium	Water, Oil, Gas

NO	PART NAME	MATERIAL
1	BODY	GG25/GGG50
2	BODY SEAT RING	BRASS/SS304
3	DISC SEAT RING	BRASS/SS304
4	DISC	DUCTILE TRON
5	COPPER WASHER	BRASS
6	DISC NUT	BRASS
7	STEM	2Cr13
8	GASKET	NBR
9	BDNNET BOLT	CARBON STEEL
10	NUT	CARBON STEEL
11	PACKING	GRAPHITE
12	GLAND	DUCTILE IRON

DN	D	D1	D2	L	b	f	Z-d	H
Ø15	Ø95	Ø65	Ø46	108	14	2	4-Ø14	204
Ø20	Ø105	Ø75	Ø56	117	16	2	4-Ø14	209
Ø25	Ø115	Ø85	Ø65	127	16	3	4-Ø14	218
Ø32	Ø140	Ø100	Ø76	140	18	3	4-Ø18	239
Ø40	Ø150	Ø110	Ø84	165	18	3	4-Ø18	248
Ø50	Ø165	Ø125	Ø99	203	20	3	4-Ø18	260
Ø65	Ø185	Ø145	Ø118	216	20	3	4-Ø18	286
Ø80	Ø200	Ø160	Ø132	241	22	3	8-Ø18	306
Ø100	Ø220	Ø180	Ø156	292	24	3	8-Ø18	331
Ø125	Ø250	Ø210	Ø184	330	26	3	8-Ø18	388
Ø150	Ø285	Ø240	Ø211	356	26	3	8-Ø22	414
Ø200	Ø340	Ø295	Ø266	495	30	3	12-Ø22	484
Ø250	Ø405	Ø355	Ø319	622	32	3	12-Ø26	533
Ø300	Ø460	Ø410	Ø370	698	32	4	12-Ø26	624

YFJ41T

GLOBE VALVE

ANSI CLASS125 DN15-DN300

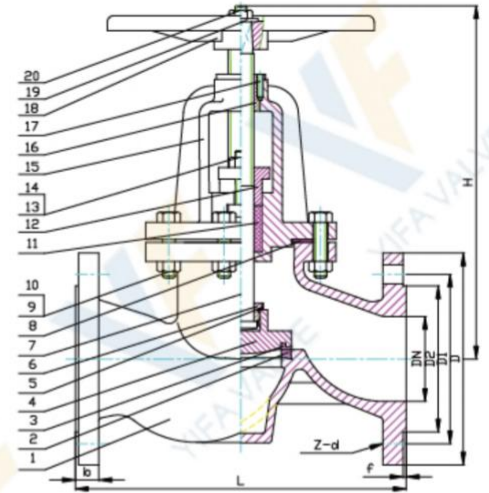

Inspection Specification

PN	16
Seat test	1.76 Mpa
Shell test	2.4 Mpa
Temp:	-10-200°C
Medium	Water,Oil, Gas

NO	PART NAME	MATERIAL
1	BODY	GG25/GGG50
2	BODY SEAT RING	BRASS/SS304
3	DISC SEAT RING	BRASS/SS304
4	DISC	DUCTILE TRON
5	COPPER WASHER	BRASS
6	DISC NUT	BRASS
7	STEM	2Cr13
8	GASKET	NBR
9	BDNNET BOLT	CARBON STEEL
10	NUT	CARBON STEEL
11	PACKING	GRAPHITE
12	GLAND	DUCTILE IRON

DN	D	D1	D2	L	b	f	Z-d	H
Ø15	Ø95	Ø65	Ø46	108	14	2	4-Ø14	204
Ø20	Ø98	Ø70	Ø56	117	16	2	4-Ø16	209
Ø25	Ø108	φ79.5	Ø65	127	16	3	4-Ø16	218
Ø32	Ø117	Ø89	Ø76	140	18	3	4-Ø16	239
Ø40	Ø127	Ø98.5	Ø84	165	18	3	4-Ø16	248
Ø50	Ø152	Ø120.5	Ø99	203	20	3	4-Ø19	260
Ø65	Ø178	Ø129.5	Ø118	216	20	3	4-Ø19	286
Ø80	Ø191	Ø152.5	Ø132	241	22	3	8-Ø19	306
Ø100	Ø229	Ø190.5	Ø156	292	24	3	8-Ø19	331
Ø125	Ø254	Ø216	Ø184	330	26	3	8-Ø22	388
Ø150	Ø279	Ø241.5	Ø211	356	26	3	8-Ø22	414
Ø200	Ø343	Ø298.5	Ø266	495	30	3	12-Ø22	484
Ø250	Ø406	Ø362	Ø319	622	32	3	12-Ø25	533
Ø300	Ø483	Ø432	Ø370	698	32	4	12-Ø25	624

YFJ41T GLOBE VALVE

JIS10K DN40-DN300

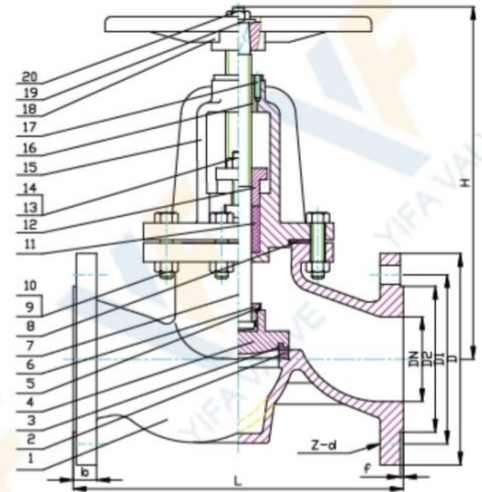

Inspection Specification

PN	16
Seat test	1.76 Mpa
Shell test	2.4 Mpa
Temp:	-10-200°C
Medium	Water, Oil, Gas

NO	PART NAME	MATERIAL
1	BODY	GG25/GGG50
2	BODY SEAT RING	BRASS/SS304
3	DISC SEAT RING	BRASS/SS304
4	DISC	DUCTILE TRON
5	COPPER WASHER	BRASS
6	DISC NUT	BRASS
7	STEM	2Cr13
8	GASKET	NBR
9	BDNNET BOLT	CARBON STEEL
10	NUT	CARBON STEEL
11	PACKING	GRAPHITE
12	GLAND	DUCTILE IRON

DN	D	D1	D2	L	b	f	Z-d	H
Ø40	Ø140	Ø105	Ø84	165	18	3	4-Ø19	248
Ø50	Ø155	Ø120	Ø99	203	20	3	4-Ø19	260
Ø65	Ø175	Ø140	Ø118	216	20	3	4-Ø19	286
Ø80	Ø185	Ø150	Ø132	241	22	3	8-Ø19	306
Ø100	Ø210	Ø175	Ø156	292	24	3	8-Ø19	331
Ø125	Ø250	Ø210	Ø184	330	26	3	8-Ø23	388
Ø150	Ø280	Ø240	Ø211	356	26	3	8-Ø23	414
Ø200	Ø330	Ø290	Ø266	495	30	3	12-Ø23	484
Ø250	Ø400	Ø355	Ø319	622	32	3	12-Ø25	533
Ø300	Ø445	Ø400	Ø370	698	32	4	16-Ø25	624

YFJ41T

GLOBE VALVE



Valve operation

1- MANUAL OPERATION

ALL GEARBOX MODELS ARE MADE OF DUCTILE CAST IRON WITH THE FOLLOWING FEATURES

- Stable Self-Locking Design.
- Superior Gear Contact Ratio.
- Changeable Bushing enables Gearbox installation in any position
- Visual position indicator



2- PNEUMATIC OPERATION

PNEUMATIC ACTUATORS ARE USED FOR FAST AND FREQUENT OPENING AND CLOSING, WHERE THE VALVE PRESSURE IS LESS THAN 6 BAR AND THE VALVE SIZE IS NOT LARGER THAN DN 800 WHICH IS TYPICALLY USED FOR WATER TREATMENT SYSTEM VALVES



3- ELECTRIC OPERATION

ELECTRIC ACTUATORS PROVIDED ON OUR VALVES COVER A WIDER RANGE OF TORQUES. SOME OPTIONAL FEATURES FOR ELECTRIC ACTUATORS



YFJ41T

GLOBE VALVE



Installation

1. Pre-Installation Inspection

Verify valve specifications (size, pressure rating, material, and standard DIN F4). Inspect the valve for any damage during transportation, especially sealing surfaces and flange faces. Ensure the valve is in the slightly open position before installation to protect the sealing surfaces. Remove all protective covers and clean internal passages.

2. Pipeline Preparation

Thoroughly clean the pipeline to remove welding slag, rust, sand, or other foreign materials. Ensure flange faces are flat, aligned, and free from damage. Confirm proper pipeline support to avoid external stress on the valve body.

3. Installation Position

The valve can be installed in horizontal or vertical pipelines. Recommended position: stem vertically upward for optimal operation and reduced wear. Avoid installation in positions with strong vibration or heavy external loads.

4. Flow Direction

Gate valves are generally bi-directional, but it is recommended to follow the indicated flow direction (if marked) for optimal performance. Ensure correct orientation to minimize turbulence and wear.

5. Flange Connection

Use appropriate gaskets suitable for working conditions (temperature, pressure). Tighten bolts evenly in a cross (diagonal) pattern. Avoid over-tightening, which may damage flange surfaces or cause deformation.

6. Operation Check After Installation

Open and close the valve slowly to ensure smooth operation. Check for abnormal resistance, noise, or vibration. Verify there is no leakage at flange connections.

7. Pressure Testing

Perform system pressure testing according to applicable standards. Increase pressure gradually to avoid sudden impact. Check sealing performance under working condition.

YFJ41T

GLOBE VALVE

Precautions / Important Notes

1. Do Not Over-Tighten (Critical for Metal Seat)

Unlike soft seat valves, excessive closing force may damage the sealing surfaces.

2. Not Suitable for Frequent Throttling

Gate valves are designed for fully open or fully closed operation, not for flow regulation.

3. Protect Sealing Surfaces from Damage

Foreign particles may scratch metal sealing surfaces and affect sealing performance.

4. Regular Operation Recommended

Operate the valve periodically to prevent sticking, especially in long-term idle systems.

5. Avoid Misalignment During Installation

Improper alignment may cause stress on the valve body and reduce service life.

6. Maintenance Under No Pressure Only

Always release system pressure before performing any maintenance or disassembly.

1. Pre-Installation Inspection

Check valve specs & ensure slightly OPEN position.



Slightly Open

2. Pipeline Preparation

CLEAN pipeline thoroughly, confirm flange alignment.



Clean & Aligned ✓

3. Correct Installation

Install STEM VERTICALLY UPWARD, avoid strong vibrations.

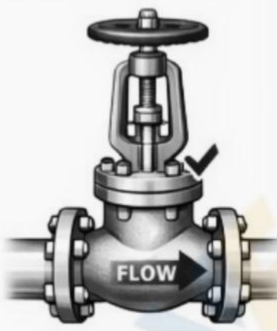

Proper Installation

4. Flow Direction

Follow FLOW DIRECTION arrow (if marked).

5. Cross Pattern

Tighten bolts in a CROSS PATTERN, avoid excessive force.



OPEN / CLOSE →

5. Flange Connection

Tighten bolts in a CROSS PATTERN, avoid excessive force.

6. Operation & Testing

OPEN / CLOSE slowly, avoid over-tightening, perform pressure testing.



CAUTION: Unlike soft seat valves, EXCESSIVE FORCE MAY DAMAGE METAL SEALING SURFACES. Avoid over-tightening when closing the valve.

Material Table-Metal

PARTS	ASME	DIN/EN	Cr	Ni	Mo	Ti	Temp.Range
	A216 WCB	GS-20 Mn 5	0.5	0.5	0.2	-	-29~425
	A216WCC	G20Mn5	0.5	0.5	0.2	-	-29~425
	A217 WC1		0.35	0.5	0.45~0.65		≤455
	A217 WC5		0.5~0.9	0.6~1	0.9~1.2	-	≤565
	A217 WC6	GS 17CrMo55	1~1.5		0.45~0.65		≤595
	A217 WC9		2~2.75	-	0.9~1.2	-	≤595
	A217 C5		4~6.5		0.45~0.65	-	≤650
	A217 C12		8~10	-	0.9~1.2	-	≤650
	A296 CA15	1.4006,1.4008	11.5~14	1	0.5	-	-20~480
	A351 CF8	G-X5CrNi ¹⁸ -10	18~21	8~11	0.05	-	≤458(540)
	A351 CF8M	X5CrNiMo18-10	18~21	9~13	2~3	-	≤425(540)
	A351 CF3	X2CrNiMo18-10	17~21	8~12	0.5	-	≤425
	A351 CF3M	GX10CrNiMo18-9	17~21	9~13	2~3		≤455
Casting	Aisi 321	X10CrNiTi18-9,1.4541	17~19	9~12	-	0.5	≤700/540
	Aisi904L	X1NiCrMoCuN25-20-6,1.4539	19~21	24~26	-		-165~600
	Aisi 316Ti	X6CrNiMoTi17-12-2	16~18	10~14	-	0.7	-165~600
	Aisi 310S	X8CrNi25-21,1.4845	24~26	19~22	-	-	≤850
	A352 LCB		-	-	-	-	-46~345
	A352 LCC		-	-	-	-	-46~345
	A352 LC1	G20Mo5,1.5419	-	-	-	-	-59~345
	A352 LC2			2~3	-		-73~200
	A352 LC3		-	3~4	-	-	-101~200
	A105(N)	C21,1.0432,S+35.8	0.3	0.4	0.12		≤450
	A350 LF1		-	-	-	-	-46~425
	A350 LF2			-			-60
	A350 LF3	10Ni14,1.5637	-	3.25~3.75	-		-101~345
	A516 Gr70	1.0539,1.0545			-	-	-46~425

Material Table-Metal

PARTS	ASME	DIN/EN	Cr	Ni	Mo	Ti	Temp.Range
Forging	A 182 F304	174,401.4301	18~20	8~11	-	-	≤800/540
	A 182 F321	X10CrNiTi18-9,1.4541	17~21	9~12	-	0.7	≤800/540
	A 182 F316	174,401.4401	16~18	10~14	2~3	-	800/540
	A 182 F316L	174,401.4404	16~18	10~15	2~3	-	≤450
	A 182 F304L	174,401.4306	18~20	8~13	-	-	≤425
	A 182F310		24~26	19~22			-29~800
	Duplex2205	X2CrNiMoN22-5-3,1.4462	21~24	4.5~6.5	2.5~3.5	-	≤450
	Duplex2304	X2CrNiN23-4,1.4362	21.5~24.5	3~5.5	0.05~0.6	-	≤425
	Duplex2507	X2CrNiMoN25-7-4,1.4410	24~26	6~8	3~5	-	-40~315
	A 182 F51	X2 CrNiMoN 22-5-3,1.4462	21~23	4.5~6.5	2.5~3.5	-	-40~315
	A 182 F1	1.5Mo3,1.5415	-	-	0.44~0.65	-	≤470
	A 182 F2	1.7335,1.7337	0.5~0.81	-	0.44~0.65	-	≤540
	A 182 F11	13CrMo4-4,1.7335	1~1.5	-	0.44~0.65	-	≤545
	A 182F22	10CrMo9-10,1.7380		0.87~1.13		-	≤550
	A 182 F12	13CrMo4-5,1.7335	0.8~1.25	-	0.44~0.65	-	≤545
	A 182 F9	X12CrMo 9-1,1.7386	8~10	-	0.9~1.1	-	≤673
	A 182 F91	1.4903,1.7332	8~9.5	0.4	0.85~1.05	-	≤673
	A 182 F5		4~6.5	0.5	0.44~0.65	-	≤550
	A 182F6a	X10Cr13	11.5~13.5	0.5	-	-	-101~480
	A 182 F44	X1CRNiMoCuN20-18-7,1.4547	19.5~20.5	17.5~18.5	6~6.5	-	≤540
Rod	Aisi 410	X12CrN13,1.4006	11.5~13.5	0.6	-	-	-101~480
	Aisi 416	X20Cr13	12~14	-	-	-	-38~350
	Aisi 420	X20Cr13	12~14	-	-	-	-101~480
	Aisi 430	X6Cr17	16~18	-	-	-	-101~480
	Aisi431	Z15CN16-02,1.4057	16~18	1.5~2.5	-	0.2	-38~425
	A276 XM-19	GX4CrNiMnN22-12-5,1.3964	20.5~23.5	11.5~13.5	1.5~3		≤550
	A 193 B7		0.75~1.2		0.15~0.25		-45.6~510
	A 193 B7M		0.75~1.2		0.15~0.25	-	-20~510
	A 193 B16		0.8~1.15	-	0.5~0.65	-	-10~600
	A320 L7		0.8~1	-	0.15~0.25	-	-101~550
	A320 B8		18~20	8~10.5	-	-	254~700
	A320 B8A		18~20	8~10.5	-	-	254~700
A320 B8M		16~18	10~14	-	-	254~816	
A320 B8T		17~19	9~12	2~3	-	196~700	
Fasteners	A 1942H		-	-	-	-	-38~450
	A 1946		11.5~13.5	-		-	-101~480
	A 1948,8A		8~10.5	18~20	-		-254~800
	A 1948M,8MA		16~18	10~14	2~3	-	-254~816
	A 1948T,8TA		17~19	9~12	-		0.3~0.6 -196~700
	D507Mo		10~16	6	2.5	-	≤450
	Alloy 20		19~21	32~38	2~3	-	≤427
	Alloy 904L		19~23	23~28	4~5	-	≤700
Surfacing welding	Uranus B-6		20.5	25.5	4.5	-	≤700
	Lewmet 25		29	-	4.5	-	≤700
	Stellite Alloy 6		27~32	3	1	-	≤700
	Inconel Alloy 625		20~23	58	8~10	0.4	≤700
	Hastelloy AlloyC-276		15.5	-	16	-	≤700

Seal parts

Parts	Characteristic	Low/High Temperature		Recommended
NR	High elasticity	-20	85	-5~70
NBR	Oil resistivity	-30	100	-15~90
EPDM	Aging resistance, ozone resistance, corrosion resistance	-40	125	-25~110
HT EPDM	Same as above, added heat resistance	-40	150	-25~135
SBR (wear-resistant)	Excellent traction performance and wear resistance	-30	100	-15~80
CR (neoprene)	Oil, heat, flame, sunlight, ozone, acid and alkali resistance	-30	125	-15~100
Hypalon	Oxidation resistance, resistance to winding and cracking	-40	120	-25~110
FPM (viton)	Chemical and most oils resistance, (except ketones & esters)	-20	200	-5~150
MVQ (silicon)	High and low temperature resistance, oil, corrosion resistance	-55	200	-30~180
PU	Chemical, oil, wear, low temperature, aging resistance	-20	120	-5~90
FEP (F46)	Chemical resistance, radiation resistance	-20	150	-5~120
PTFE	Heat, cold, acid, alkali, organic solvents resistant	-60	180	-45~150
RPTFE	Corrosion resistance, low friction coefficient	-60	180	-45~150
PFA	Excellent chemical corrosion resistance, low friction coefficient	-196	200	-60~180
PPL	High temperature and chemical corrosion resistance	-60	230	-45~200
UPVC	Corrosion and pressure resistance, hygiene	-30	100	-15~80
CPVC	Corrosion and pressure resistance, hygiene	-30	110	-15~95
PVDF	Anti aging and chemical resistance	-30	100	-15~70
PEEK	High temperature and chemical resistance	-60	300	-45~260
Flexible graphite	Cold and hot resistant, corrosion resistant, self-lubricating	-200	600	-60~550
Ceramic fiber	Fire, high temperature resistance, low thermal conductivity	-200	1050	-60~950
Metal to metal	High temperature, high pressure, wear, corrosion resistance	Refer to the material		

Unit: Degree

Inspection Standards and Requirements

Inspection Standards and Requirements							
		ISO5208:2008 / GB/T13927			API598-2004		
Shell strength	Medium temperature	5~40			5~40		
	Medium	Water, kerosene, air, suitable gas			Water, kerosene, air, suitable gas		
	Test pressure	Norminal pressure (PN)×1.5			Norminal pressure×1.5		
	Minimum duration of the test	DN	Seconds		NPS	Check valve	Others
		≤50	15		≤2"	60	15
		65~200	60		2½"~6"	60	60
≥250		180		8"~12"	60	120	
Assessment	No visible leakage allowed			No visible leakage allowed			
Back seal	Test pressure	DN	PN	Pressure	NPS	Class	Pressure
		≤80	All	0.6Mpa	All	≤300	0.4~0.7Mpa
		100~200	≤5.0	0.6Mpa			
		100~200	>5.0	PN × 1.1		>300	Class x 1.1
	≥250	All	PN × 1.1				
Assessment	No visible leakage allowed			No visible leakage allowed			
High pressure sealing test	Test pressure	DN	PN	Pressure	Class	Ductile iron	Steel
		≤80	All	PN × 1.1 (liquid)	150	1.7 Mpa	Class x 1.1
		100~200	≤5.0	0.5~0.7Mpa (air)			
		100~200	>5.0	PN × 1.1 (liquid)	300	4.4 Mpa	
		≥250	All	0.5~0.7Mpa (air)			
		Minimum duration of the test	DN	Metal seal	Resilient seal	NPS	Check valve
	≤50	15	15	≤2"	60	15	
	65~200	30	15	2½"~6"	60	60	
	250~450	60	30	8"~12"	60	120	
	≥500	120	60	≥14"	120	120	
	Assessment	Class (level)	Liquid leakage	Air leakage	NPS	Liquid & Air	Liquid & Air
		A	No visible leakage allowed (mm3/s)		≤2"	Liquid:3cm³/in. min Air:0.042m³/ in.h	0 drop(bubble)/ min
		B	DN x 0.01	DN x 0.3	2½"~6"		12 & 24
		C	DN x 0.03	DN x 3	8"~12"		20 & 40
	D	DN x 0.1	DN x 30	≥14"		2 & 4 / in ·min	
	Low pressure sealing test	Medium	Air, suitable gas			Air, suitable gas	
Test pressure		0.5~0.7 Mpa			0.4~0.7 Mpa		
		DN	Metal seal	Resilient seal	NPS	Check valve	Others
		≤50	15	15	≤2"	60	15
Minimum duration of the test		65~200	30	15	2½"~6"	60	60
		250~450	60	30	8"~12"	60	120
		≥500	120	60	≥14"	120	120
Assessment		Class (level)	Air leakage		NPS	Air leakage	
		A	No visible leakage allowed (mm3/s)		≤2"		0 bubble /min
		B	DN x 0.3		2½"~6"	0.042 m3/in ·h	24
	C	DN x 3		8"~12"		40	
D	DN x 30		≥14"		4 / in ·min		

Flange connection dimensions

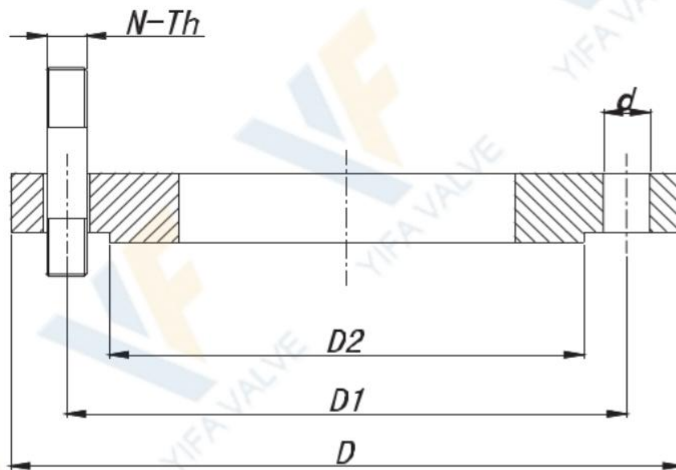

- D- Flange outer diameter
- D1- Bolt circle diameter
- D2- Diameter of sealing surface
- N-Th Bolt size
- d- Bolt hole diameter

PN10 (DIN2632)

DN	D	D1	D2	N-Th	d
50	165	125	102	4-M16	Φ18
65	185	145	122	4-M16	Φ18
80	200	160	138	8-M16	Φ18
100	220	180	158	8-M16	Φ18
125	250	210	188	8-M16	Φ18
150	285	240	212	8-M20	Φ23
200	340	295	268	12-M20	Φ23
250	405	355	320	12-M24	Φ27
300	460	410	378	12-M24	Φ27
350	520	470	438	16-M24	Φ27
400	580	525	490	16-M27	Φ30
450	640	585	550	20-M27	Φ30
500	715	650	610	20-M30	Φ33
600	840	770	725	20-M33	Φ36
700	910	840	795	24-M33	Φ36
800	1025	950	900	24-M36	Φ39
900	1125	1050	1000	28-M36	Φ39
1000	1255	1170	1115	28-M39	Φ42
1200	1485	1390	1330	32-M45	Φ48
1400	1685	1590	1530	36-M45	Φ48
1600	1930	1820	1750	40-M52	Φ56
1800	2130	2020	1950	44-M52	Φ56
2000	2345	2230	2150	48-M56	Φ62

PN16 (DIN2632)

DN	D	D1	D2	N-Th	d
50	165	125	102	4-M16	Φ18
65	185	145	122	4-M16	Φ18
80	200	160	138	8-M16	Φ18
100	220	180	158	8-M16	Φ18
125	250	210	188	8-M16	Φ18
150	285	240	212	8-M20	Φ23
200	340	295	268	12-M20	Φ23
250	405	355	320	12-M24	Φ27
300	460	410	378	12-M24	Φ27
350	520	470	438	16-M24	Φ27
400	580	525	490	16-M27	Φ30
450	640	585	550	20-M27	Φ30
500	715	650	610	20-M30	Φ33
600	840	770	725	20-M33	Φ36
700	910	840	795	24-M33	Φ36
800	1025	950	900	24-M36	Φ39
900	1125	1050	1000	28-M36	Φ39
1000	1255	1170	1115	28-M39	Φ42
1200	1485	1390	1330	32-M45	Φ48
1400	1685	1590	1530	36-M45	Φ48
1600	1930	1820	1750	40-M52	Φ56
1800	2130	2020	1950	44-M52	Φ56
2000	2345	2230	2150	48-M56	Φ62

Flange connection dimensions

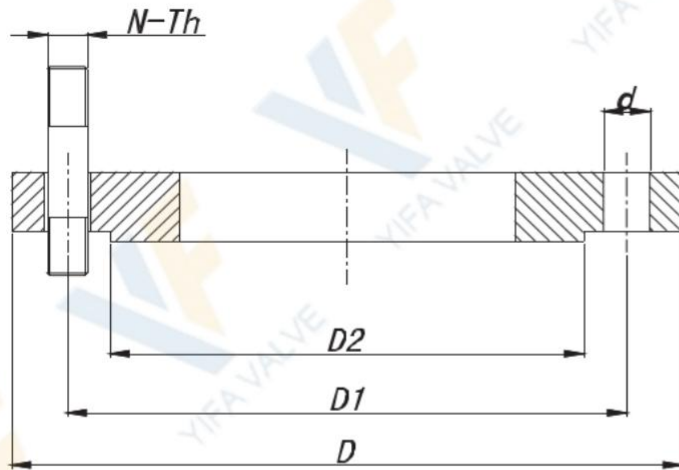

- D- Flange outer diameter
- D1- Bolt circle diameter
- D2- Diameter of sealing surface
- N-Th Bolt size
- d- Bolt hole diameter

PN10 (GB/T9113.1)

DN	D	D1	D2	N-Th	d
50	165	125	99	4-M16	Φ18
65	185	145	118	4-M16	Φ18
80	200	160	132	8-M16	Φ18
100	220	180	156	8-M16	Φ18
125	250	210	184	8-M16	Φ18
150	285	240	211	8-M20	Φ23
200	340	295	266	8-M20	Φ23
250	395	350	319	12-M20	Φ23
300	445	400	370	12-M20	Φ23
350	505	460	429	16-M20	Φ23
400	565	515	480	16-M24	Φ27
450	615	565	530	20-M24	Φ27
500	670	620	582	20-M24	Φ27
600	780	725	682	20-M27	Φ30
700	895	840	794	24-M27	Φ30
800	1015	950	901	24-M30	Φ33
900	1115	1050	1001	28-M30	Φ33
1000	1230	1160	1112	28-M33	Φ36
1200	1455	1380	1328	32-M36	Φ39

PN16 (GB/T9113.1)

DN	D	D1	D2	N-Th	d
50	165	125	99	4-M16	Φ18
65	185	145	118	4-M16	Φ18
80	200	160	132	8-M16	Φ18
100	220	180	156	8-M16	Φ18
125	250	210	184	8-M16	Φ18
150	285	240	211	8-M20	Φ23
200	340	295	266	12-M20	Φ23
250	405	355	319	12-M24	Φ27
300	460	410	370	12-M24	Φ27
350	520	470	429	16-M24	Φ27
400	580	525	480	16-M27	Φ30
450	640	585	548	20-M27	Φ30
500	715	650	609	20-M30	Φ33
600	840	770	720	20-M33	Φ36
700	910	840	794	24-M33	Φ36
800	1025	950	901	24-M36	Φ39
900	1125	1050	1001	28-M36	Φ39
1000	1255	1170	1112	28-M39	Φ42
1200	1485	1390	1328	32-M45	Φ48

Flange and connection details

GB/T9113.1 PN10

DN	D1	n°	M	T	●	⊕	+
50	125	4	M-16	10	2--0		-2
65	145	4	M-16	10	2--0		-2
80	160	8	M-16	12	2--4		-2
100	180	8	M-16	12	2--4		-2
125	210	8	M-16	14	2--4		-2
150	240	8	M-20	14	2--4		-2
200	295	8	M-20	14	2--4		-2
250	350	12	M-20	18	4--6		-2
300	400	12	M-20	21	4--6		-2
350	460	16	M-20	21	6--8		-2
400	515	16	M-24	25	6--8		-2
450	565	20	M-24	25	8--10		-2
500	620	20	M-24	26	8--10		-2
600	725	20	M-27	26	8--10		-2
700	840	24	M-27	22	10--12		-2
800	950	24	M-30	22	10--12		-2
900	1050	28	M-30	22	12--12		-4
1000	1160	28	M-33	22	12--12		-4
1200	1380	32	M-36	33	14--14		-4

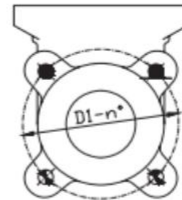

DN50-65

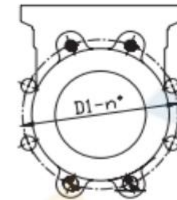

DN80-200

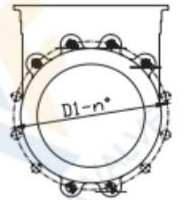

DN250-300



DN350-400



DN450-600

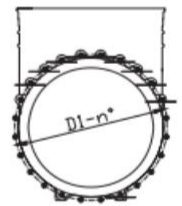

DN700-800

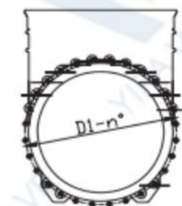

DN900-1000

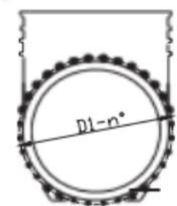

DN1200

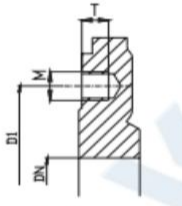

Blind hole tapping

- Blind hole thread
- ⊕ Through hole
- ⦿ Drilling through

GB/T9113.1 PN16

DN	D1	n°	M	T	●	⊕	+
50	125	4	M-16	10	2--0		-2
65	145	4	M-16	10	2--0		-2
80	160	8	M-16	12	2--4		-2
100	180	8	M-16	12	2--4		-2
125	210	8	M-16	14	2--4		-2
150	240	8	M-20	14	2--4		-2
200	295	12	M-20	14	2--4		-2
250	355	12	M-24	18	4--6		-2
300	410	12	M-24	21	4--6		-2
350	470	16	M-24	21	6--8		-2
400	525	16	M-27	25	6--8		-2
450	585	20	M-27	25	8--10		-2
500	640	20	M-30	26	8--10		-2
600	725	20	M-33	26	8--10		-2
700	840	24	M-33	22	10--12		-2
800	950	24	M-36	22	10--12		-2
900	1050	28	M-36	22	12--12		-4
1000	1170	28	M-39	22	12--12		-4
1200	1390	32	M-45	33	14--14		-4

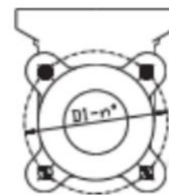

DN50-65



DN80-150

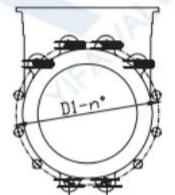

DN200-300



DN350-400



DN450-600

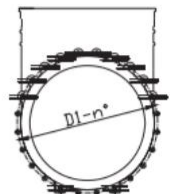

DN700-800

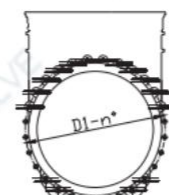

DN900-1000

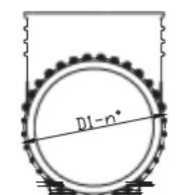

DN1200

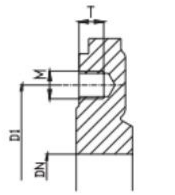

Blind hole tapping

Flange connection dimensions

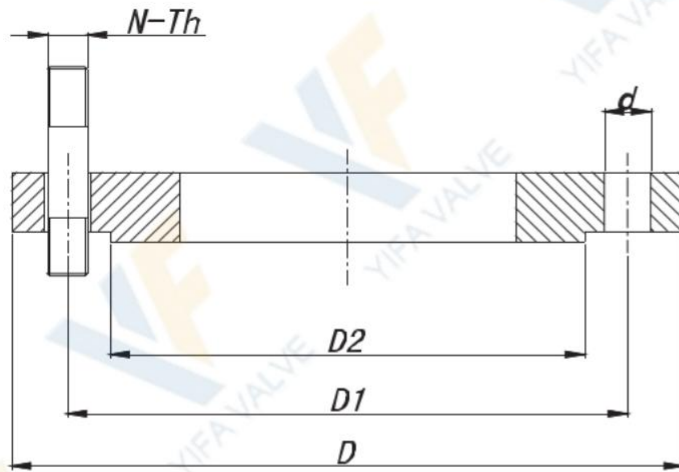

- D- Flange outer diameter
- D1- Bolt circle diameter
- D2- Diameter of sealing surface
- N-Th Bolt size
- d- Bolt hole diameter

10K (JIS B2239-2004)

150Lb (ANSI B16.5 & ASME B16.47)

DN	D	D1	D2	N-Th	d
50	155	120	96	4-M16	Φ19
65	175	140	116	4-M16	Φ19
80	185	150	126	8-M16	Φ19
100	210	175	151	8-M16	Φ19
125	250	210	182	8-M20	Φ23
150	280	240	212	8-M20	Φ23
200	330	290	262	12-M20	Φ23
250	400	355	324	12-M22	Φ25
300	445	400	368	16-M22	Φ25
350	490	445	413	16-M22	Φ25
400	560	510	475	16-M24	Φ27
450	620	565	530	20-M24	Φ27
500	675	620	585	20-M24	Φ27
550	745	680	640	20-M30	Φ33
600	795	730	690	24-M30	Φ33
650	845	780	740	24-M30	Φ33
700	905	840	800	24-M30	Φ33
750	970	900	855	24-M30	Φ33
800	1020	950	905	28-M30	Φ33
850	1070	1000	955	28-M30	Φ33
900	1120	1050	1005	28-M30	Φ33
1000	1235	1160	1110	28-M36	Φ39
1100	1345	1270	1220	28-M36	Φ39
1200	1465	1380	1325	32-M36	Φ39
1350	1630	1540	1480	36-M42	Φ45
1500	1795	1700	1635	40-M42	Φ45

DN	D	D1	D2	N-Th	d
2D	153	120.5	92	4-5/8DUNC	Φ19
2.5D	178	139.5	105	4-5/8DUNC	Φ19
3D	191	152.5	127	4-5/8DUNC	Φ19
4D	229	190.5	157	8-5/8DUNC	Φ19
5D	254	216	186	8-3/4DUNC	Φ22
6D	280	241.5	216	8-3/4DUNC	Φ22
8D	343	298.5	270	8-3/4DUNC	Φ22
10D	407	362	324	12-7/8DUNC	Φ25
12D	483	432	381	12-7/8DUNC	Φ25
14D	534	476	413	12-1DUNC	Φ29
16D	597	539.5	470	16-1DUNC	Φ29
18D	635	578	534	16-1 1/8DUNC	Φ32
20D	699	635	584	20-1 1/8DUNC	Φ32
24D	813	749.5	692	20-1 1/4DUNC	Φ35
26D	870	806.5	749	24-1 1/4DUNC	Φ35
28D	925	863.5	800	28-1 1/4DUNC	Φ35
30D	985	914.5	857	28-1 1/4DUNC	Φ35
32D	1060	978	914	28-1 1/2DUNC	Φ41
36D	1170	1086	1022	32-1 1/2DUNC	Φ41
40D	1290	1200	1124	36-1 1/2DUNC	Φ41
42D	1345	1257	1194	36-1 1/2DUNC	Φ41
44D	1405	1314	1245	40-1 1/2DUNC	Φ41
48D	1510	1422	1359	44-1 1/2DUNC	Φ41
52D	1625	1537	1461	44-1 3/4DUNC	Φ47
56D	1745	1651	1575	48-1 3/4DUNC	Φ47
60D	1855	1759	1676	52-1 3/4DUNC	Φ47

Flange and connection details

JIS B2239-2004 10K

DN	D1	n°	M	T	●	⊕	+
50	120	4	M-16	10	2--0		-2
65	140	4	M-16	10	2--0		-2
80	150	8	M-16	12	2--4		-2
100	175	8	M-16	12	2--4		-2
125	210	8	M-20	14	2--4		-2
150	240	8	M-20	14	2--4		-2
200	290	12	M-20	14	2--4		-2
250	355	12	M-22	18	4--6		-2
300	400	16	M-22	21	4--6		-2
350	445	16	M-22	21	6--8		-2
400	510	16	M-24	25	6--8		-2
450	565	20	M-24	25	8--10		-2
500	620	20	M-24	26	8--10		-2
600	730	24	M-30	26	8--10		-2
700	840	24	M-30	22	10--12		-2
800	950	28	M-30	22	10--12		-2
900	1050	28	M-30	22	12--12		-4
1000	1160	28	M-30	22	12--12		-4
1200	1380	32	M-36	33	14--14		-4

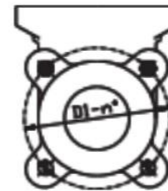

DN50-65



DN80-150

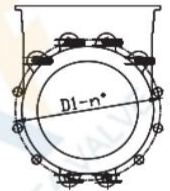

DN200-250

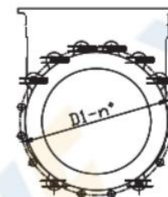

DN300-400



DN450-500

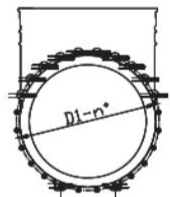

DN600-700



DN800-1000

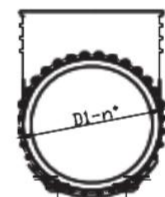

DN1200

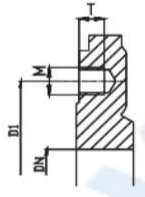

Blind hole tapping

- Blind hole thread
- ⊕ Through hole
- ⦿ Drilling through

ANSI B16.5 & ASME B16.47 150Lb

DN	D1	n°	M	T	●	⊕	+
2"	120.5	4	5/8" UNC	10	2--0		-2
2 1/2"	139.5	4	5/8" UNC	10	2--0		-2
3"	152.5	4	5/8" UNC	12	2--4		-2
4"	190.5	8	5/8" UNC	12	2--4		-2
5"	216	8	3/4" UNC	14	2--4		-2
6"	241.5	8	3/4" UNC	14	2--4		-2
8"	298.5	8	3/4" UNC	14	2--4		-2
10"	362	12	7/8" UNC	18	4--6		-2
12"	432	12	7/8" UNC	21	4--6		-2
14"	476	12	1" UNC	21	6--8		-2
16"	540	16	1" UNC	25	6--8		-2
18"	578	16	1 1/8" UNC	25	8--10		-2
20"	635	20	1 1/8" UNC	26	8--10		-2
24"	749.5	20	1 1/4" UNC	26	8--10		-2
28"	863.5	28	1 1/4" UNC	26	10--12		-2
30"	914	28	1 1/4" UNC	22	10--12		-2
32"	978	28	1 1/2" UNC	22	12--12		-4
36"	1085.8	32	1 1/2" UNC	22	12--12		-4
40"	1200.2	36	1 1/2" UNC	30	14--14		-4

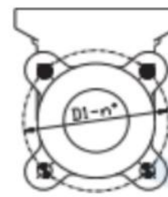

2"-3"



4"-8"

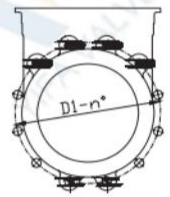

10"-14"

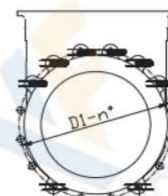

16"-18"

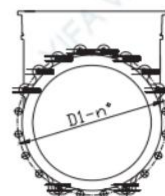

20"-24"

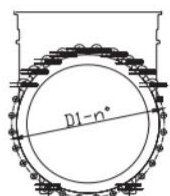

28"-32"

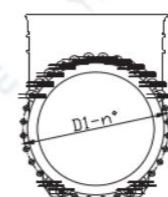

36"

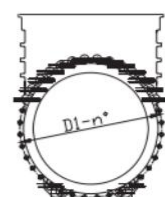

40"

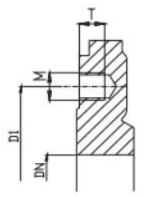

Blind hole tapping



No.2 Road, Jinnan District
Industrial Zone, Xiaozhan
Town, Jinnan District, Tianjin,
China



0086 0379 69926196



valve@yifavalves.com