

# YFZ41X GATE VALVE

## Product Description

YFZ41X rising stem resilient gate valve is designed for reliable sealing, smooth operation, and long-term durability in watersupply and pipeline systems.

Featuring a fully rubber-coated wedge, corrosion-resistant epoxy coating, and a non-rising stem structure, the valve ensures tightshut-off, low torque operation, and space-saving installation.

It is widely used in water treatment, municipalinfrastructure, fire protectionsystems, and general pipeline applications.



### Technical Data

|                |   |
|----------------|---|
| Size range     | DN40-DN1600                                       |
| Pressure range | PN 10-16/Class 150/JIS10K                         |
| Temperature    | EPDM : -10°C to +100 °C<br>NBR: - 10°C to + 80 °C |
| Design         | EN1171, DIN3352, EN1074-1                         |
| Face to face   | EN558-1 Series 14/15, DIN3202 F4/F5               |
| Connection     | EN 1092-2, ISO7005-2                              |
| Coating        | Electrostatic Powder Epoxy                        |
| Testing        | EN 12266, ISO5208                                 |
| Medium         | Water,oil,Gas                                     |

### Application Range

- HVAC Systems
- Pumping Stations
- Water Treatment Plants
- Reservoirs and Tanks
- Irrigation
- Industrial Applications

### Related Products

- YFZ44T MATEL SEAT GATE VALVE
- YFPZ73X KNIFE GATE VALVE
- YFH44X SWING CHECK VALVE



HVAC



IRRIGATION



POTABLE WATER



INDUSTRY

# YFZ41X

## GATE VALVE

### Product Description

---

#### 1. High-Strength, Corrosion-Resistant Body

Constructed from GGG40/50 ductile iron (2450 MPa tensile strength, >10% elongation) with full internal/external >250um epoxy coating, the valve boasts exceptional toughness, cracking resistance and long-term corrosion protection.

#### 2. Zero-Leakage Sealing System

Fully EPDM-coated wedge (>50% rubber content) and resilient soft-seal design ensure bubble-tight shut-off, with reliable sealing that resists rubber detachment during long-term operation, ideal for water systems.

#### 3. Space-Saving, Durable Stem Assembly

Non-rising stem design saves space for underground/confined installations; made from corrosion-resistant 2Cr13 stainless steel, it features triple O-ring sealing (enabling under-pressure replacement) and a brass nut for smooth, jam-free operation.

#### 4. Low-Torque, Versatile Operation

Optimized internal structure minimizes friction, allowing effortless manual or actuator-controlled operation with low torque requirements.

#### 5. Long Service Life & Minimal Maintenance

Premium materials, robust sealing and wear-resistant components combine to deliver an extended service life with significantly reduced maintenance needs.



# YFZ41X

## GATE VALVE

### BS5163 PN10/16 DN40-DN1000

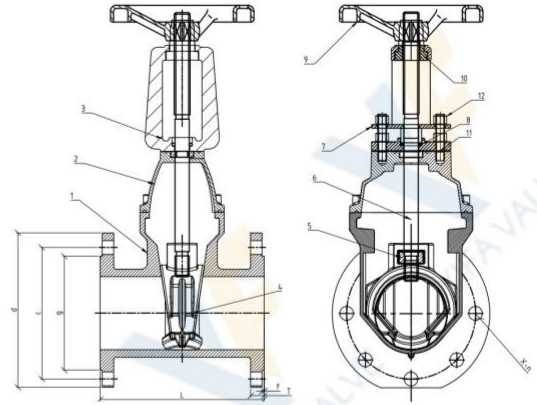

#### Inspection Specification

|            |                 |
|------------|-----------------|
| PN         | 16              |
| Seat test  | 1.76 Mpa        |
| Shell test | 2.4 Mpa         |
| Temp:      | -10-120°C       |
| Medium     | Water, Oil, Gas |

| ITEM | Part Name     | Material     |
|------|---------------|--------------|
| 1    | Body          | GGG50        |
| 2    | Bonnet        | GGG50        |
| 3    | Sealing Ring  | NBR          |
| 4    | Disc          | GGG50+EPDM   |
| 5    | Stem Nut      | BRASS        |
| 6    | Stem          | SS420        |
| 7    | Holding Ring  | BRASS        |
| 8    | "O" Ring      | Silica Gel   |
| 9    | Handwheel     | Carbon steel |
| 10   | Bonnet Gasket | EPDM         |
| 11   | Bolt          | Carbon Steel |
| 12   | Bolt          | SS201        |

| DN   | L-mm | a-mm | d-mm      |           | C-mm   |        | x-n |   | T-mm | f-mm | g-mm |
|------|------|------|-----------|-----------|--------|--------|-----|---|------|------|------|
|      |      |      | PN10/PN16 | PN10/PN16 | 10kg   | 16kg   |     |   |      |      |      |
| 50   | 178  | 50   | 165       | 125       | 4-φ18  |        | 19  | 2 | 99   |      |      |
| 65   | 190  | 65   | 185       | 145       | 4-φ18  |        | 19  | 2 | 118  |      |      |
| 80   | 203  | 80   | 200       | 160       | 4-φ18  | 8-φ18  | 19  | 3 | 132  |      |      |
| 100  | 229  | 100  | 220       | 180       | 8-φ18  |        | 19  | 3 | 156  |      |      |
| 125  | 254  | 125  | 250       | 210       | 8-φ18  |        | 19  | 3 | 184  |      |      |
| 150  | 267  | 150  | 285       | 240       | 8-φ23  |        | 19  | 3 | 211  |      |      |
| 200  | 292  | 200  | 340       | 295       | 8-Ø23  | 12-Ø23 | 21  | 3 | 266  |      |      |
| 250  | 330  | 250  | 395       | 350/355   | 12-φ23 | 12-φ26 | 22  | 3 | 319  |      |      |
| 300  | 356  | 300  | 445       | 400/410   | 12-φ23 | 12-φ26 | 25  | 4 | 370  |      |      |
| 350  | 381  | 350  | 515       | 460/470   | 16-Ø23 | 16-φ26 | 25  | 4 | 430  |      |      |
| 400  | 406  | 400  | 580       | 515/525   | 16-φ26 | 16-φ31 | 28  | 4 | 475  |      |      |
| 450  | 432  | 450  | 650       | 565/585   | 20-φ26 | 20-φ31 | 29  | 4 | 530  |      |      |
| 500  | 457  | 500  | 670/715   | 620/650   | 20-Ø26 | 20-Ø34 | 29  | 4 | 580  |      |      |
| 600  | 508  | 600  | 780/810   | 725/770   | 20-φ30 | 20-φ36 | 38  | 4 | 680  |      |      |
| 800  | 660  | 800  | 1010/1025 | 950       | 24-Ø34 | 24-φ40 | 44  | 5 | 905  |      |      |
| 900  | 711  | 900  | 1115/1125 | 1050      | 28-φ34 | 28-φ40 | 46  | 5 | 1001 |      |      |
| 1000 | 811  | 1000 | 1230/1255 | 1160/1170 | 28-φ37 | 28-φ43 | 50  | 5 | 1112 |      |      |

# YFZ41X GATE VALVE

DIN3352 PN10/16 DN40-DN600

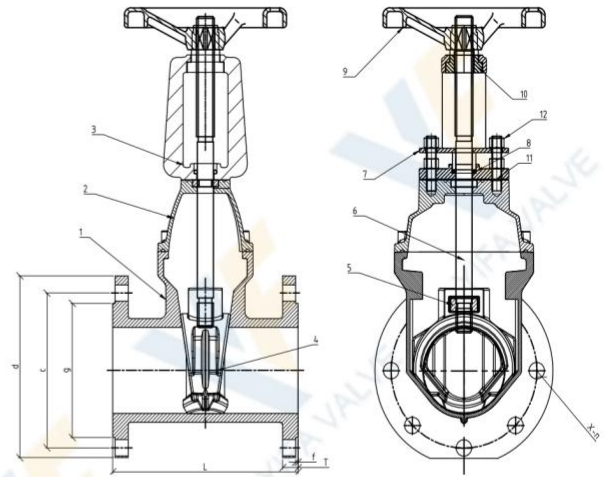

### Inspection Specification

|            |                 |
|------------|-----------------|
| PN         | 16              |
| Seat test  | 1.76 Mpa        |
| Shell test | 2.4 Mpa         |
| Temp:      | -10-120°C       |
| Medium     | Water, Oil, Gas |

| ITEM | Part Name     | Material     |
|------|---------------|--------------|
| 1    | Body          | GGG50        |
| 2    | Bonnet        | GGG50        |
| 3    | Sealing Ring  | NBR          |
| 4    | Disc          | GGG50+EPDM   |
| 5    | Stem Nut      | BRASS        |
| 6    | Stem          | SS420        |
| 7    | Holding Ring  | BRASS        |
| 8    | "O" Ring      | Silica Qel   |
| 9    | Handwheel     | Carbon steel |
| 10   | Bonnet Gasket | EPDM         |
| 11   | Bolt          | Carbon Steel |
| 12   | Bolt          | SS201        |

| DN  | L   |     | h    | a   | d       | c       | x-n           | +    | f | g       |
|-----|-----|-----|------|-----|---------|---------|---------------|------|---|---------|
|     | F5  | F4  |      |     |         |         |               |      |   |         |
| 40  | 240 | 150 | 240  | 40  | 150     | 110     | 4-Ø19         | 16   | 2 | 84      |
| 50  | 250 | 150 | 241  | 50  | 165     | 125     | 4-Ø19         | 16.5 | 2 | 99      |
| 65  | 270 | 170 | 270  | 65  | 185     | 145     | 4-Ø19         | 17   | 2 | 118     |
| 80  | 280 | 180 | 222  | 80  | 200     | 160     | 4-Ø19/8-Ø19   | 19   | 3 | 132     |
| 100 | 300 | 190 | 333  | 100 | 220     | 180     | 8-Ø19         | 20   | 3 | 156     |
| 125 | 325 | 200 | 384  | 125 | 250     | 210     | 8-Ø19         | 20   | 3 | 184     |
| 150 | 350 | 210 | 420  | 150 | 285     | 240     | 8-Ø23         | 20   | 3 | 211     |
| 200 | 400 | 230 | 512  | 200 | 340     | 295     | 8-Ø23/12-Ø23  | 20   | 3 | 266     |
| 250 | 450 | 250 | 602  | 250 | 405     | 350/355 | 12-Ø23/12-Ø26 | 25   | 3 | 319     |
| 300 | 500 | 270 | 705  | 300 | 460     | 400/410 | 12-Ø23/12-Ø26 | 28   | 4 | 370     |
| 350 | 550 | 290 | 782  | 350 | 520     | 460/470 | 16-Ø23/16-Ø26 | 28   | 4 | 430     |
| 400 | 600 | 310 | 880  | 400 | 582     | 515/525 | 16-Ø25/16-Ø30 | 28   | 4 | 475     |
| 450 | 650 | 330 | 1000 | 450 | 615/640 | 565/585 | 20-Ø26/20-Ø30 | 32   | 4 | 565/585 |
| 500 | 700 | 350 | 1055 | 500 | 670/715 | 620/650 | 20-Ø26/20-Ø30 | 32   | 4 | 580     |
| 600 | 800 | 390 | 1260 | 600 | 780/840 | 725/700 | 20-Ø30/20-Ø36 | 38   | 4 | 680     |

# YFZ41X

## GATE VALVE



### Valve operation

---

#### 1- MANUAL OPERATION

ALL GEARBOX MODELS ARE MADE OF DUCTILE CAST IRON WITH THE FOLLOWING FEATURES

Stable Self-Locking Design.

Superior Gear Contact Ratio.

Changeable Bushing enables Gearbox installation in any position



#### 2- PNEUMATIC OPERATION

PNEUMATIC ACTUATORS ARE USED FOR FAST AND FREQUENT OPENING AND CLOSING, WHERE THE VALVE PRESSURE IS LESS THAN 6 BAR AND THE VALVE SIZE IS NOT LARGER THAN DN 800 WHICH IS TYPICALLY USED FOR WATER TREATMENT SYSTEM VALVES

#### 3- ELECTRIC OPERATION

ELECTRIC ACTUATORS PROVIDED ON OUR VALVES COVER A WIDER RANGE OF TORQUES. SOME OPTIONAL FEATURES FOR ELECTRIC ACTUATORS

# YFZ41X

## GATE VALVE



### Installation

---

#### 1. Pre-Installation Inspection

Verify valve specifications (size, pressure rating, material, and standard DIN F4). Inspect the valve for any damage during transportation, especially sealing surfaces and flange faces. Ensure the valve is in the slightly open position before installation to protect the sealing surfaces. Remove all protective covers and clean internal passages.

#### 2. Pipeline Preparation

Thoroughly clean the pipeline to remove welding slag, rust, sand, or other foreign materials. Ensure flange faces are flat, aligned, and free from damage. Confirm proper pipeline support to avoid external stress on the valve body.

#### 3. Installation Position

The valve can be installed in horizontal or vertical pipelines. Recommended position: stem vertically upward for optimal operation and reduced wear. Avoid installation in positions with strong vibration or heavy external loads.

#### 4. Flow Direction

Gate valves are generally bi-directional, but it is recommended to follow the indicated flow direction (if marked) for optimal performance. Ensure correct orientation to minimize turbulence and wear.

#### 5. Flange Connection

Use appropriate gaskets suitable for working conditions (temperature, pressure). Tighten bolts evenly in a cross (diagonal) pattern. Avoid over-tightening, which may damage flange surfaces or cause deformation.

#### 6. Operation Check After Installation

Open and close the valve slowly to ensure smooth operation. Check for abnormal resistance, noise, or vibration. Verify there is no leakage at flange connections.

#### 7. Pressure Testing

Perform system pressure testing according to applicable standards. Increase pressure gradually to avoid sudden impact. Check sealing performance under working condition.

# YFZ41X

## GATE VALVE

### Precautions / Important Notes

#### 1. Do Not Over-Tighten (Critical for Metal Seat)

Unlike soft seat valves, excessive closing force may damage the sealing surfaces.

#### 2. Not Suitable for Frequent Throttling

Gate valves are designed for fully open or fully closed operation, not for flow regulation.

#### 3. Protect Sealing Surfaces from Damage

Foreign particles may scratch metal sealing surfaces and affect sealing performance.

#### 4. Regular Operation Recommended

Operate the valve periodically to prevent sticking, especially in long-term idle systems.

#### 5. Avoid Misalignment During Installation

Improper alignment may cause stress on the valve body and reduce service life.

#### 6. Maintenance Under No Pressure Only

Always release system pressure before performing any maintenance or disassembly.

#### 1. Pre-Installation Inspection

Check valve specs & ensure slightly OPEN position.



Slightly Open

#### 2. Pipeline Preparation

CLEAN pipeline thoroughly, confirm flange alignment.



Clean & Aligned ✓

#### 3. Correct Installation

Install STEM VERTICALLY UPWARD, avoid strong vibrations.

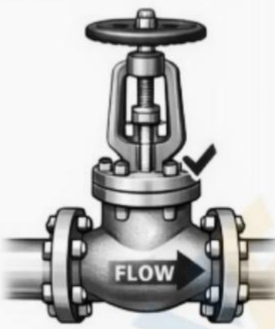

Proper Installation

#### 4. Flow Direction

Follow FLOW DIRECTION arrow (if marked).

#### 5. Cross Pattern

Tighten bolts in a CROSS PATTERN, avoid excessive force.



OPEN / CLOSE →

#### 5. Flange Connection

Tighten bolts in a CROSS PATTERN, avoid excessive force.

#### 6. Operation & Testing

OPEN / CLOSE slowly, avoid over-tightening, perform pressure testing.



**CAUTION:** Unlike soft seat valves, EXCESSIVE FORCE MAY DAMAGE METAL SEALING SURFACES. Avoid over-tightening when closing the valve.

## Material Table-Metal

| PARTS               | ASME | DIN/EN                     | Cr      | Ni        | Mo        | Ti  | Temp.Range |
|---------------------|------|----------------------------|---------|-----------|-----------|-----|------------|
| A216 WCB            |      | GS-20 Mn 5                 | 0.5     | 0.5       | 0.2       | -   | -29~425    |
| A216WCC             |      | G20Mn5                     | 0.5     | 0.5       | 0.2       | -   | -29~425    |
| A217 WC1            |      |                            | 0.35    | 0.5       | 0.45~0.65 |     | ≤455       |
| A217 WC5            |      |                            | 0.5~0.9 | 0.6~1     | 0.9~1.2   | -   | ≤565       |
| A217 WC6            |      | GS 17CrMo55                | 1~1.5   |           | 0.45~0.65 |     | ≤595       |
| A217 WC9            |      |                            | 2~2.75  | -         | 0.9~1.2   | -   | ≤595       |
| A217 C5             |      |                            | 4~6.5   |           | 0.45~0.65 | -   | ≤650       |
| A217 C12            |      |                            | 8~10    | -         | 0.9~1.2   | -   | ≤650       |
| A296 CA15           |      | 1.4006,1.4008              | 11.5~14 | 1         | 0.5       | -   | -20~480    |
| A351 CF8            |      | G-X5CrNi <sup>18</sup> -10 | 18~21   | 8~11      | 0.05      | -   | ≤458(540)  |
| A351 CF8M           |      | X5CrNiMo18-10              | 18~21   | 9~13      | 2~3       | -   | ≤425(540)  |
| A351 CF3            |      | X2CrNiMo18-10              | 17~21   | 8~12      | 0.5       | -   | ≤425       |
| A351 CF3M           |      | GX10CrNiMo18-9             | 17~21   | 9~13      | 2~3       |     | ≤455       |
| Casting<br>Aisi 321 |      | X10CrNiTi18-9,1.4541       | 17~19   | 9~12      | -         | 0.5 | ≤700/540   |
| Aisi904L            |      | X1NiCrMoCuN25-20-6,1.4539  | 19~21   | 24~26     | -         |     | -165~600   |
| Aisi 316Ti          |      | X6CrNiMoTi17-12-2          | 16~18   | 10~14     | -         | 0.7 | -165~600   |
| Aisi 310S           |      | X8CrNi25-21,1.4845         | 24~26   | 19~22     | -         | -   | ≤850       |
| A352 LCB            |      |                            | -       | -         | -         | -   | -46~345    |
| A352 LCC            |      |                            | -       | -         | -         | -   | -46~345    |
| A352 LC1            |      | G20Mo5,1.5419              | -       | -         | -         | -   | -59~345    |
| A352 LC2            |      |                            |         | 2~3       | -         |     | -73~200    |
| A352 LC3            |      |                            | -       | 3~4       | -         | -   | -101~200   |
| A105(N)             |      | C21,1.0432,S+35.8          | 0.3     | 0.4       | 0.12      |     | ≤450       |
| A350 LF1            |      |                            | -       | -         | -         | -   | -46~425    |
| A350 LF2            |      |                            |         | -         |           |     | -60        |
| A350 LF3            |      | 10Ni14,1.5637              | -       | 3.25~3.75 | -         |     | -101~345   |
| A516 Gr70           |      | 1.0539,1.0545              |         |           | -         | -   | -46~425    |

## Material Table-Metal

| PARTS             | ASME                 | DIN/EN                    | Cr        | Ni             | Mo        | Ti      | Temp.Range       |
|-------------------|----------------------|---------------------------|-----------|----------------|-----------|---------|------------------|
| Forging           | A 182 F304           | 174,401.4301              | 18~20     | 8~11           | -         | -       | ≤800/540         |
|                   | A 182 F321           | X10CrNiTi18-9,1.4541      | 17~21     | 9~12           | -         | 0.7     | ≤800/540         |
|                   | A 182 F316           | 174,401.4401              | 16~18     | 10~14          | 2~3       | -       | 800/540          |
|                   | A 182 F316L          | 174,401.4404              | 16~18     | 10~15          | 2~3       | -       | ≤450             |
|                   | A 182 F304L          | 174,401.4306              | 18~20     | 8~13           | -         | -       | ≤425             |
|                   | A 182F310            |                           | 24~26     | 19~22          |           |         | -29~800          |
|                   | Duplex2205           | X2CrNiMoN22-5-3,1.4462    | 21~24     | 4.5~6.5        | 2.5~3.5   | -       | ≤450             |
|                   | Duplex2304           | X2CrNiN23-4,1.4362        | 21.5~24.5 | 3~5.5          | 0.05~0.6  | -       | ≤425             |
|                   | Duplex2507           | X2CrNiMoN25-7-4,1.4410    | 24~26     | 6~8            | 3~5       | -       | -40~315          |
|                   | A 182 F51            | X2 CrNiMoN 22-5-3,1.4462  | 21~23     | 4.5~6.5        | 2.5~3.5   | -       | -40~315          |
|                   | A 182 F1             | 1.5Mo3,1.5415             | -         | -              | 0.44~0.65 | -       | ≤470             |
|                   | A 182 F2             | 1.7335,1.7337             | 0.5~0.81  | -              | 0.44~0.65 | -       | ≤540             |
|                   | A 182 F11            | 13CrMo4-4,1.7335          | 1~1.5     | -              | 0.44~0.65 | -       | ≤545             |
|                   | A 182F22             | 10CrMo9-10,1.7380         |           | 0.87~1.13      |           | -       | ≤550             |
|                   | A 182 F12            | 13CrMo4-5,1.7335          | 0.8~1.25  | -              | 0.44~0.65 | -       | ≤545             |
|                   | A 182 F9             | X12CrMo 9-1,1.7386        | 8~10      | -              | 0.9~1.1   | -       | ≤673             |
|                   | A 182 F91            | 1.4903,1.7332             | 8~9.5     | 0.4            | 0.85~1.05 | -       | ≤673             |
|                   | A 182 F5             |                           | 4~6.5     | 0.5            | 0.44~0.65 | -       | ≤550             |
|                   | A 182F6a             | X10Cr13                   | 11.5~13.5 | 0.5            | -         | -       | -101~480         |
|                   | A 182 F44            | X1CRNiMoCuN20-18-7,1.4547 | 19.5~20.5 | 17.5~18.5      | 6~6.5     | -       | ≤540             |
| Rod               | Aisi 410             | X12CrN13,1.4006           | 11.5~13.5 | 0.6            | -         | -       | -101~480         |
|                   | Aisi 416             | X20Cr13                   | 12~14     | -              | -         | -       | -38~350          |
|                   | Aisi 420             | X20Cr13                   | 12~14     | -              | -         | -       | -101~480         |
|                   | Aisi 430             | X6Cr17                    | 16~18     | -              | -         | -       | -101~480         |
|                   | Aisi431              | Z15CN16-02,1.4057         | 16~18     | 1.5~2.5        | -         | 0.2     | -38~425          |
|                   | A276 XM-19           | GX4CrNiMnN22-12-5,1.3964  | 20.5~23.5 | 11.5~13.5~13.5 | 1.5~3     |         | ≤550             |
|                   | A 193 B7             |                           | 0.75~1.2  |                | 0.15~0.25 |         | -45.6~510        |
|                   | A 193 B7M            |                           | 0.75~1.2  |                | 0.15~0.25 | -       | -20~510          |
|                   | A 193 B16            |                           | 0.8~1.15  | -              | 0.5~0.65  | -       | -10~600          |
|                   | A320 L7              |                           | 0.8~1     | -              | 0.15~0.25 | -       | -101~550         |
|                   | A320 B8              |                           | 18~20     | 8~10.5         | -         | -       | 254~700          |
|                   | A320 B8A             |                           | 18~20     | 8~10.5         | -         | -       | 254~700          |
|                   | A320 B8M             |                           | 16~18     | 10~14          | -         | -       | 254~816          |
| A320 B8T          |                      | 17~19                     | 9~12      | 2~3            | -         | 196~700 |                  |
| Fasteners         | A 1942H              |                           | -         | -              | -         | -       | -38~450          |
|                   | A 1946               |                           | 11.5~13.5 | -              |           | -       | -101~480         |
|                   | A 1948,8A            |                           | 8~10.5    | 18~20          | -         |         | -254~800         |
|                   | A 1948M,8MA          |                           | 16~18     | 10~14          | 2~3       | -       | -254~816         |
|                   | A 1948T,8TA          |                           | 17~19     | 9~12           | -         |         | 0.3~0.6 -196~700 |
|                   | D507Mo               |                           | 10~16     | 6              | 2.5       | -       | ≤450             |
|                   | Alloy 20             |                           | 19~21     | 32~38          | 2~3       | -       | ≤427             |
|                   | Alloy 904L           |                           | 19~23     | 23~28          | 4~5       | -       | ≤700             |
| Surfacing welding | Uranus B-6           |                           | 20.5      | 25.5           | 4.5       | -       | ≤700             |
|                   | Lewmet 25            |                           | 29        | -              | 4.5       | -       | ≤700             |
|                   | Stellite Alloy 6     |                           | 27~32     | 3              | 1         | -       | ≤700             |
|                   | Inconel Alloy 625    |                           | 20~23     | 58             | 8~10      | 0.4     | ≤700             |
|                   | Hastelloy AlloyC-276 |                           | 15.5      | -              | 16        | -       | ≤700             |

## Seal parts

| Parts                | Characteristic  | Low/High Temperature  |      | Recommended |
|----------------------|---|-----------------------|------|-------------|
|                      |   |                       |      |             |
| NR                   | High elasticity   | -20                   | 85   | -5~70       |
| NBR                  | Oil resistivity   | -30                   | 100  | -15~90      |
| EPDM                 | Aging resistance, ozone resistance, corrosion resistance          | -40                   | 125  | -25~110     |
| HT EPDM              | Same as above, added heat resistance                              | -40                   | 150  | -25~135     |
| SBR (wear-resistant) | Excellent traction performance and wear resistance                | -30                   | 100  | -15~80      |
| CR (neoprene)        | Oil, heat, flame, sunlight, ozone, acid and alkali resistance     | -30                   | 125  | -15~100     |
| Hypalon              | Oxidation resistance, resistance to winding and cracking          | -40                   | 120  | -25~110     |
| FPM (viton)          | Chemical and most oils resistance, (except ketones & esters)      | -20                   | 200  | -5~150      |
| MVQ (silicon)        | High and low temperature resistance, oil, corrosion resistance    | -55                   | 200  | -30~180     |
| PU                   | Chemical, oil, wear, low temperature, aging resistance            | -20                   | 120  | -5~90       |
| FEP (F46)            | Chemical resistance, radiation resistance                         | -20                   | 150  | -5~120      |
| PTFE                 | Heat, cold, acid, alkali, organic solvents resistant              | -60                   | 180  | -45~150     |
| RPTFE                | Corrosion resistance, low friction coefficient                    | -60                   | 180  | -45~150     |
| PFA                  | Excellent chemical corrosion resistance, low friction coefficient | -196                  | 200  | -60~180     |
| PPL                  | High temperature and chemical corrosion resistance                | -60                   | 230  | -45~200     |
| UPVC                 | Corrosion and pressure resistance, hygiene                        | -30                   | 100  | -15~80      |
| CPVC                 | Corrosion and pressure resistance, hygiene                        | -30                   | 110  | -15~95      |
| PVDF                 | Anti aging and chemical resistance                                | -30                   | 100  | -15~70      |
| PEEK                 | High temperature and chemical resistance                          | -60                   | 300  | -45~260     |
| Flexible graphite    | Cold and hot resistant, corrosion resistant, self-lubricating     | -200                  | 600  | -60~550     |
| Ceramic fiber        | Fire, high temperature resistance, low thermal conductivity       | -200                  | 1050 | -60~950     |
| Metal to metal       | High temperature, high pressure, wear, corrosion resistance       | Refer to the material |      |             |

Unit: Degree

## Inspection Standards and Requirements

| Inspection Standards and Requirements |                              |                                    |                                    |                            |                                    |   |                           |
|---------------------------------------|------------------------------|------------------------------------|------------------------------------|----------------------------|------------------------------------|---|---------------------------|
|                                       |                              | ISO5208:2008 / GB/T13927           |                                    |                            | API598-2004                        |   |                           |
| Shell strength                        | Medium temperature           | 5~40                               |                                    |                            | 5~40                               |   |                           |
|                                       | Medium                       | Water, kerosene, air, suitable gas |                                    |                            | Water, kerosene, air, suitable gas |   |                           |
|                                       | Test pressure                | Norminal pressure (PN)×1.5         |                                    |                            | Norminal pressure×1.5              |   |                           |
|                                       | Minimum duration of the test | DN                                 | Seconds                            |                            | NPS                                | Check valve                                 | Others                    |
|                                       |                              | ≤50                                | 15                                 |                            | ≤2"                                | 60  | 15                        |
|                                       |                              | 65~200                             | 60                                 |                            | 2½"~6"                             | 60  | 60                        |
| ≥250                                  |                              | 180                                |                                    | 8"~12"                     | 60                                 | 120   |                           |
| Assessment                            | No visible leakage allowed   |                                    |                                    | No visible leakage allowed |                                    |   |                           |
| Back seal                             | Test pressure                | DN                                 | PN                                 | Pressure                   | NPS                                | Class                                       | Pressure                  |
|                                       |                              | ≤80                                | All                                | 0.6Mpa                     | All                                | ≤300  | 0.4~0.7Mpa                |
|                                       |                              | 100~200                            | ≤5.0                               | 0.6Mpa                     |                                    |   |                           |
|                                       |                              | 100~200                            | >5.0                               | PN × 1.1                   |                                    | >300  | Class x 1.1               |
|                                       | ≥250                         | All                                | PN × 1.1                           |                            |                                    |   |                           |
| Assessment                            | No visible leakage allowed   |                                    |                                    | No visible leakage allowed |                                    |   |                           |
| High pressure sealing test            | Test pressure                | DN                                 | PN                                 | Pressure                   | Class                              | Ductile iron                                | Steel                     |
|                                       |                              | ≤80                                | All                                | PN × 1.1 (liquid)          | 150                                | 1.7 Mpa                                     | Class x 1.1               |
|                                       |                              | 100~200                            | ≤5.0                               | 0.5~0.7Mpa (air)           |                                    |   |                           |
|                                       |                              | 100~200                            | >5.0                               | PN × 1.1 (liquid)          | 300                                | 4.4 Mpa                                     |                           |
|                                       |                              | ≥250                               | All                                | 0.5~0.7Mpa (air)           |                                    |   |                           |
|                                       |                              | 100~200                            | >5.0                               | PN × 1.1 (liquid)          | 300                                | 4.4 Mpa                                     |                           |
|                                       | ≥250                         | All                                | PN × 1.1 (liquid)                  |                            |                                    |   |                           |
|                                       | Minimum duration of the test | DN                                 | Metal seal                         | Resilient seal             | NPS                                | Check valve                                 | Others                    |
|                                       |                              | ≤50                                | 15                                 | 15                         | ≤2"                                | 60  | 15                        |
|                                       |                              | 65~200                             | 30                                 | 15                         | 2½"~6"                             | 60  | 60                        |
|                                       |                              | 250~450                            | 60                                 | 30                         | 8"~12"                             | 60  | 120                       |
|                                       |                              | ≥500                               | 120                                | 60                         | ≥14"                               | 120   | 120                       |
|                                       | Assessment                   | Class (level)                      | Liquid leakage                     | Air leakage                | NPS                                | Liquid & Air                                | Liquid & Air              |
|                                       |                              | A                                  | No visible leakage allowed (mm3/s) |                            | ≤2"                                | Liquid:3cm³/in.<br>min Air:0.042m³/<br>in.h | 0<br>drop(bubble)/<br>min |
|                                       |                              | B                                  | DN x 0.01                          | DN x 0.3                   | 2½"~6"                             |   | 12 & 24                   |
|                                       |                              | C                                  | DN x 0.03                          | DN x 3                     | 8"~12"                             |   | 20 & 40                   |
| D                                     | DN x 0.1                     | DN x 30                            | ≥14"                               |                            |                                    | 2 & 4 / in ·min                             |                           |
| Low pressure sealing test             | Medium                       | Air, suitable gas                  |                                    |                            | Air, suitable gas                  |   |                           |
|                                       | Test pressure                | 0.5~0.7 Mpa                        |                                    |                            | 0.4~0.7 Mpa                        |   |                           |
|                                       |                              | DN                                 | Metal seal                         | Resilient seal             | NPS                                | Check valve                                 | Others                    |
|                                       |                              | ≤50                                | 15                                 | 15                         | ≤2"                                | 60  | 15                        |
|                                       | Minimum duration of the test | 65~200                             | 30                                 | 15                         | 2½"~6"                             | 60  | 60                        |
|                                       |                              | 250~450                            | 60                                 | 30                         | 8"~12"                             | 60  | 120                       |
|                                       |                              | ≥500                               | 120                                | 60                         | ≥14"                               | 120   | 120                       |
|                                       | Assessment                   | Class (level)                      | Air leakage                        |                            | NPS                                | Air leakage                                 |                           |
|                                       |                              | A                                  | No visible leakage allowed (mm3/s) |                            | ≤2"                                |   | 0 bubble /min             |
|                                       |                              | B                                  | DN x 0.3                           |                            | 2½"~6"                             | 0.042 m3/in ·h                              | 24                        |
| C                                     |                              | DN x 3                             |                                    | 8"~12"                     |                                    | 40  |                           |
| D                                     |                              | DN x 30                            |                                    | ≥14"                       |                                    | 4 / in ·min                                 |                           |

## Flange connection dimensions

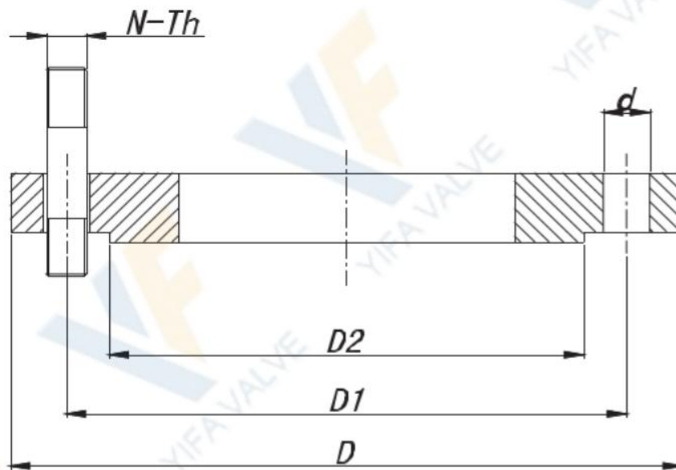

- D- Flange outer diameter
- D1- Bolt circle diameter
- D2- Diameter of sealing surface
- N-Th Bolt size
- d- Bolt hole diameter

### PN10 (DIN2632)

| DN   | D    | D1   | D2   | N-Th   | d   |
|------|------|------|------|--------|-----|
| DN   | D    | D1   | D2   | N-Th   | d   |
| 50   | 165  | 125  | 102  | 4-M16  | Φ18 |
| 65   | 185  | 145  | 122  | 4-M16  | Φ18 |
| 80   | 200  | 160  | 138  | 8-M16  | Φ18 |
| 100  | 220  | 180  | 158  | 8-M16  | Φ18 |
| 125  | 250  | 210  | 188  | 8-M16  | Φ18 |
| 150  | 285  | 240  | 212  | 8-M20  | Φ23 |
| 200  | 340  | 295  | 268  | 12-M20 | Φ23 |
| 250  | 405  | 355  | 320  | 12-M24 | Φ27 |
| 300  | 460  | 410  | 378  | 12-M24 | Φ27 |
| 350  | 520  | 470  | 438  | 16-M24 | Φ27 |
| 400  | 580  | 525  | 490  | 16-M27 | Φ30 |
| 450  | 640  | 585  | 550  | 20-M27 | Φ30 |
| 500  | 715  | 650  | 610  | 20-M30 | Φ33 |
| 600  | 840  | 770  | 725  | 20-M33 | Φ36 |
| 700  | 910  | 840  | 795  | 24-M33 | Φ36 |
| 800  | 1025 | 950  | 900  | 24-M36 | Φ39 |
| 900  | 1125 | 1050 | 1000 | 28-M36 | Φ39 |
| 1000 | 1255 | 1170 | 1115 | 28-M39 | Φ42 |
| 1200 | 1485 | 1390 | 1330 | 32-M45 | Φ48 |
| 1400 | 1685 | 1590 | 1530 | 36-M45 | Φ48 |
| 1600 | 1930 | 1820 | 1750 | 40-M52 | Φ56 |
| 1800 | 2130 | 2020 | 1950 | 44-M52 | Φ56 |
| 2000 | 2345 | 2230 | 2150 | 48-M56 | Φ62 |

### PN16 (DIN2632)

| DN   | D    | D1   | D2   | N-Th   | d   |
|------|------|------|------|--------|-----|
| DN   | D    | D1   | D2   | N-Th   | d   |
| 50   | 165  | 125  | 102  | 4-M16  | Φ18 |
| 65   | 185  | 145  | 122  | 4-M16  | Φ18 |
| 80   | 200  | 160  | 138  | 8-M16  | Φ18 |
| 100  | 220  | 180  | 158  | 8-M16  | Φ18 |
| 125  | 250  | 210  | 188  | 8-M16  | Φ18 |
| 150  | 285  | 240  | 212  | 8-M20  | Φ23 |
| 200  | 340  | 295  | 268  | 12-M20 | Φ23 |
| 250  | 405  | 355  | 320  | 12-M24 | Φ27 |
| 300  | 460  | 410  | 378  | 12-M24 | Φ27 |
| 350  | 520  | 470  | 438  | 16-M24 | Φ27 |
| 400  | 580  | 525  | 490  | 16-M27 | Φ30 |
| 450  | 640  | 585  | 550  | 20-M27 | Φ30 |
| 500  | 715  | 650  | 610  | 20-M30 | Φ33 |
| 600  | 840  | 770  | 725  | 20-M33 | Φ36 |
| 700  | 910  | 840  | 795  | 24-M33 | Φ36 |
| 800  | 1025 | 950  | 900  | 24-M36 | Φ39 |
| 900  | 1125 | 1050 | 1000 | 28-M36 | Φ39 |
| 1000 | 1255 | 1170 | 1115 | 28-M39 | Φ42 |
| 1200 | 1485 | 1390 | 1330 | 32-M45 | Φ48 |
| 1400 | 1685 | 1590 | 1530 | 36-M45 | Φ48 |
| 1600 | 1930 | 1820 | 1750 | 40-M52 | Φ56 |
| 1800 | 2130 | 2020 | 1950 | 44-M52 | Φ56 |
| 2000 | 2345 | 2230 | 2150 | 48-M56 | Φ62 |

## Flange connection dimensions

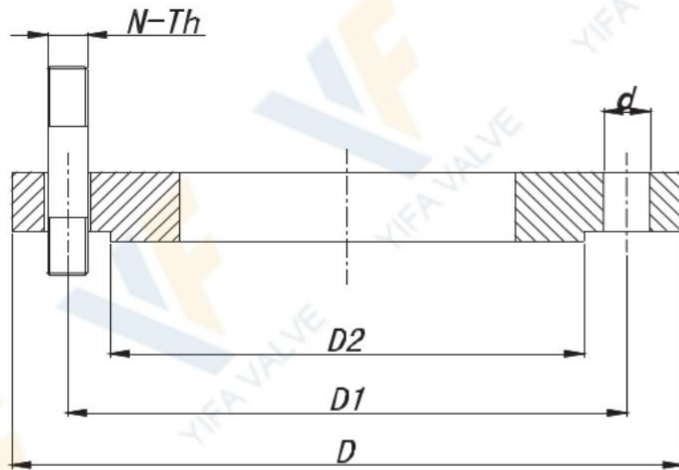

- D- Flange outer diameter
- D1- Bolt circle diameter
- D2- Diameter of sealing surface
- N-Th Bolt size
- d- Bolt hole diameter

PN10 (GB/T9113.1)

| DN   | D    | D1   | D2   | N-Th   | d   |
|------|------|------|------|--------|-----|
| 50   | 165  | 125  | 99   | 4-M16  | Φ18 |
| 65   | 185  | 145  | 118  | 4-M16  | Φ18 |
| 80   | 200  | 160  | 132  | 8-M16  | Φ18 |
| 100  | 220  | 180  | 156  | 8-M16  | Φ18 |
| 125  | 250  | 210  | 184  | 8-M16  | Φ18 |
| 150  | 285  | 240  | 211  | 8-M20  | Φ23 |
| 200  | 340  | 295  | 266  | 8-M20  | Φ23 |
| 250  | 395  | 350  | 319  | 12-M20 | Φ23 |
| 300  | 445  | 400  | 370  | 12-M20 | Φ23 |
| 350  | 505  | 460  | 429  | 16-M20 | Φ23 |
| 400  | 565  | 515  | 480  | 16-M24 | Φ27 |
| 450  | 615  | 565  | 530  | 20-M24 | Φ27 |
| 500  | 670  | 620  | 582  | 20-M24 | Φ27 |
| 600  | 780  | 725  | 682  | 20-M27 | Φ30 |
| 700  | 895  | 840  | 794  | 24-M27 | Φ30 |
| 800  | 1015 | 950  | 901  | 24-M30 | Φ33 |
| 900  | 1115 | 1050 | 1001 | 28-M30 | Φ33 |
| 1000 | 1230 | 1160 | 1112 | 28-M33 | Φ36 |
| 1200 | 1455 | 1380 | 1328 | 32-M36 | Φ39 |

PN16 (GB/T9113.1)

| DN   | D    | D1   | D2   | N-Th   | d   |
|------|------|------|------|--------|-----|
| 50   | 165  | 125  | 99   | 4-M16  | Φ18 |
| 65   | 185  | 145  | 118  | 4-M16  | Φ18 |
| 80   | 200  | 160  | 132  | 8-M16  | Φ18 |
| 100  | 220  | 180  | 156  | 8-M16  | Φ18 |
| 125  | 250  | 210  | 184  | 8-M16  | Φ18 |
| 150  | 285  | 240  | 211  | 8-M20  | Φ23 |
| 200  | 340  | 295  | 266  | 12-M20 | Φ23 |
| 250  | 405  | 355  | 319  | 12-M24 | Φ27 |
| 300  | 460  | 410  | 370  | 12-M24 | Φ27 |
| 350  | 520  | 470  | 429  | 16-M24 | Φ27 |
| 400  | 580  | 525  | 480  | 16-M27 | Φ30 |
| 450  | 640  | 585  | 548  | 20-M27 | Φ30 |
| 500  | 715  | 650  | 609  | 20-M30 | Φ33 |
| 600  | 840  | 770  | 720  | 20-M33 | Φ36 |
| 700  | 910  | 840  | 794  | 24-M33 | Φ36 |
| 800  | 1025 | 950  | 901  | 24-M36 | Φ39 |
| 900  | 1125 | 1050 | 1001 | 28-M36 | Φ39 |
| 1000 | 1255 | 1170 | 1112 | 28-M39 | Φ42 |
| 1200 | 1485 | 1390 | 1328 | 32-M45 | Φ48 |

## Flange and connection details

### GB/T9113.1 PN10

| DN   | D1   | n° | M    | T  | ●      | ⊕ | +  |
|------|------|----|------|----|--------|---|----|
| 50   | 125  | 4  | M-16 | 10 | 2--0   |   | -2 |
| 65   | 145  | 4  | M-16 | 10 | 2--0   |   | -2 |
| 80   | 160  | 8  | M-16 | 12 | 2--4   |   | -2 |
| 100  | 180  | 8  | M-16 | 12 | 2--4   |   | -2 |
| 125  | 210  | 8  | M-16 | 14 | 2--4   |   | -2 |
| 150  | 240  | 8  | M-20 | 14 | 2--4   |   | -2 |
| 200  | 295  | 8  | M-20 | 14 | 2--4   |   | -2 |
| 250  | 350  | 12 | M-20 | 18 | 4--6   |   | -2 |
| 300  | 400  | 12 | M-20 | 21 | 4--6   |   | -2 |
| 350  | 460  | 16 | M-20 | 21 | 6--8   |   | -2 |
| 400  | 515  | 16 | M-24 | 25 | 6--8   |   | -2 |
| 450  | 565  | 20 | M-24 | 25 | 8--10  |   | -2 |
| 500  | 620  | 20 | M-24 | 26 | 8--10  |   | -2 |
| 600  | 725  | 20 | M-27 | 26 | 8--10  |   | -2 |
| 700  | 840  | 24 | M-27 | 22 | 10--12 |   | -2 |
| 800  | 950  | 24 | M-30 | 22 | 10--12 |   | -2 |
| 900  | 1050 | 28 | M-30 | 22 | 12--12 |   | -4 |
| 1000 | 1160 | 28 | M-33 | 22 | 12--12 |   | -4 |
| 1200 | 1380 | 32 | M-36 | 33 | 14--14 |   | -4 |

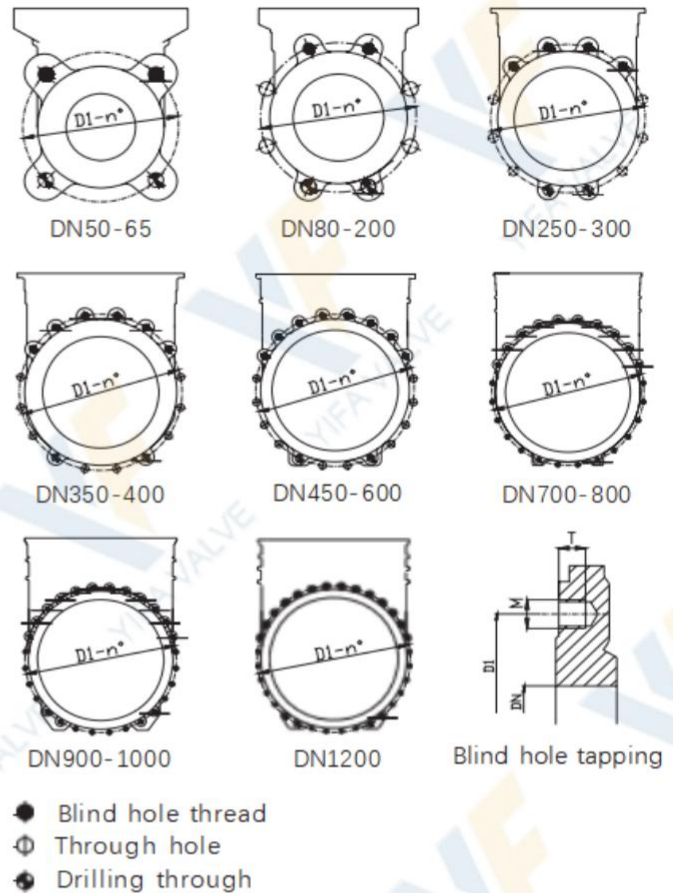

### GB/T9113.1 PN16

| DN   | D1   | n° | M    | T  | ●      | ⊕ | +  |
|------|------|----|------|----|--------|---|----|
| 50   | 125  | 4  | M-16 | 10 | 2--0   |   | -2 |
| 65   | 145  | 4  | M-16 | 10 | 2--0   |   | -2 |
| 80   | 160  | 8  | M-16 | 12 | 2--4   |   | -2 |
| 100  | 180  | 8  | M-16 | 12 | 2--4   |   | -2 |
| 125  | 210  | 8  | M-16 | 14 | 2--4   |   | -2 |
| 150  | 240  | 8  | M-20 | 14 | 2--4   |   | -2 |
| 200  | 295  | 12 | M-20 | 14 | 2--4   |   | -2 |
| 250  | 355  | 12 | M-24 | 18 | 4--6   |   | -2 |
| 300  | 410  | 12 | M-24 | 21 | 4--6   |   | -2 |
| 350  | 470  | 16 | M-24 | 21 | 6--8   |   | -2 |
| 400  | 525  | 16 | M-27 | 25 | 6--8   |   | -2 |
| 450  | 585  | 20 | M-27 | 25 | 8--10  |   | -2 |
| 500  | 640  | 20 | M-30 | 26 | 8--10  |   | -2 |
| 600  | 725  | 20 | M-33 | 26 | 8--10  |   | -2 |
| 700  | 840  | 24 | M-33 | 22 | 10--12 |   | -2 |
| 800  | 950  | 24 | M-36 | 22 | 10--12 |   | -2 |
| 900  | 1050 | 28 | M-36 | 22 | 12--12 |   | -4 |
| 1000 | 1170 | 28 | M-39 | 22 | 12--12 |   | -4 |
| 1200 | 1390 | 32 | M-45 | 33 | 14--14 |   | -4 |

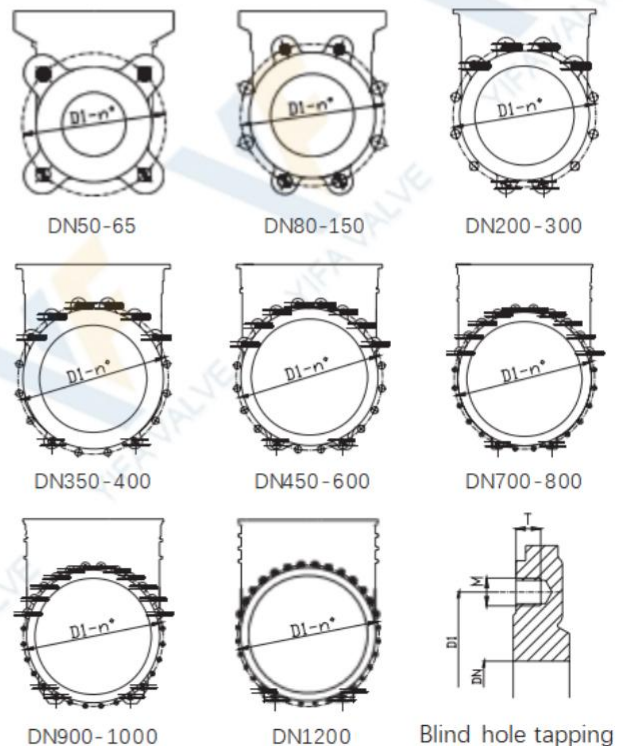

## Flange connection dimensions

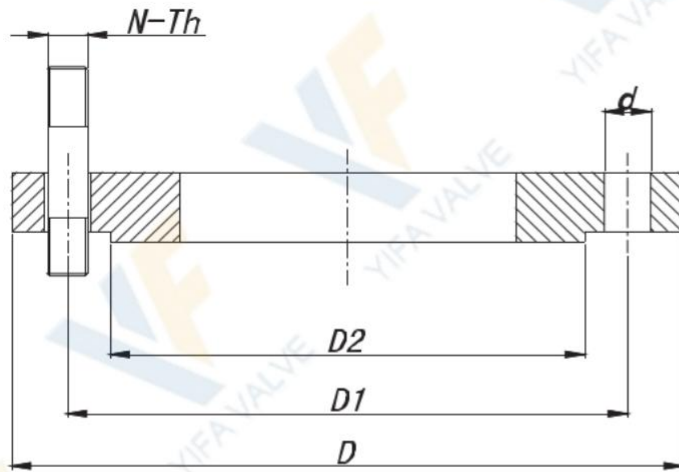

- D- Flange outer diameter
- D1- Bolt circle diameter
- D2- Diameter of sealing surface
- N-Th Bolt size
- d- Bolt hole diameter

10K (JIS B2239-2004)

150Lb (ANSI B16.5 & ASME B16.47)

| DN   | D    | D1   | D2   | N-Th   | d   |
|------|------|------|------|--------|-----|
| 50   | 155  | 120  | 96   | 4-M16  | Φ19 |
| 65   | 175  | 140  | 116  | 4-M16  | Φ19 |
| 80   | 185  | 150  | 126  | 8-M16  | Φ19 |
| 100  | 210  | 175  | 151  | 8-M16  | Φ19 |
| 125  | 250  | 210  | 182  | 8-M20  | Φ23 |
| 150  | 280  | 240  | 212  | 8-M20  | Φ23 |
| 200  | 330  | 290  | 262  | 12-M20 | Φ23 |
| 250  | 400  | 355  | 324  | 12-M22 | Φ25 |
| 300  | 445  | 400  | 368  | 16-M22 | Φ25 |
| 350  | 490  | 445  | 413  | 16-M22 | Φ25 |
| 400  | 560  | 510  | 475  | 16-M24 | Φ27 |
| 450  | 620  | 565  | 530  | 20-M24 | Φ27 |
| 500  | 675  | 620  | 585  | 20-M24 | Φ27 |
| 550  | 745  | 680  | 640  | 20-M30 | Φ33 |
| 600  | 795  | 730  | 690  | 24-M30 | Φ33 |
| 650  | 845  | 780  | 740  | 24-M30 | Φ33 |
| 700  | 905  | 840  | 800  | 24-M30 | Φ33 |
| 750  | 970  | 900  | 855  | 24-M30 | Φ33 |
| 800  | 1020 | 950  | 905  | 28-M30 | Φ33 |
| 850  | 1070 | 1000 | 955  | 28-M30 | Φ33 |
| 900  | 1120 | 1050 | 1005 | 28-M30 | Φ33 |
| 1000 | 1235 | 1160 | 1110 | 28-M36 | Φ39 |
| 1100 | 1345 | 1270 | 1220 | 28-M36 | Φ39 |
| 1200 | 1465 | 1380 | 1325 | 32-M36 | Φ39 |
| 1350 | 1630 | 1540 | 1480 | 36-M42 | Φ45 |
| 1500 | 1795 | 1700 | 1635 | 40-M42 | Φ45 |

| DN   | D    | D1    | D2   | N-Th         | d   |
|------|------|-------|------|--------------|-----|
| 2D   | 153  | 120.5 | 92   | 4-5/8DUNC    | Φ19 |
| 2.5D | 178  | 139.5 | 105  | 4-5/8DUNC    | Φ19 |
| 3D   | 191  | 152.5 | 127  | 4-5/8DUNC    | Φ19 |
| 4D   | 229  | 190.5 | 157  | 8-5/8DUNC    | Φ19 |
| 5D   | 254  | 216   | 186  | 8-3/4DUNC    | Φ22 |
| 6D   | 280  | 241.5 | 216  | 8-3/4DUNC    | Φ22 |
| 8D   | 343  | 298.5 | 270  | 8-3/4DUNC    | Φ22 |
| 10D  | 407  | 362   | 324  | 12-7/8DUNC   | Φ25 |
| 12D  | 483  | 432   | 381  | 12-7/8DUNC   | Φ25 |
| 14D  | 534  | 476   | 413  | 12-1DUNC     | Φ29 |
| 16D  | 597  | 539.5 | 470  | 16-1DUNC     | Φ29 |
| 18D  | 635  | 578   | 534  | 16-1 1/8DUNC | Φ32 |
| 20D  | 699  | 635   | 584  | 20-1 1/8DUNC | Φ32 |
| 24D  | 813  | 749.5 | 692  | 20-1 1/4DUNC | Φ35 |
| 26D  | 870  | 806.5 | 749  | 24-1 1/4DUNC | Φ35 |
| 28D  | 925  | 863.5 | 800  | 28-1 1/4DUNC | Φ35 |
| 30D  | 985  | 914.5 | 857  | 28-1 1/4DUNC | Φ35 |
| 32D  | 1060 | 978   | 914  | 28-1 1/2DUNC | Φ41 |
| 36D  | 1170 | 1086  | 1022 | 32-1 1/2DUNC | Φ41 |
| 40D  | 1290 | 1200  | 1124 | 36-1 1/2DUNC | Φ41 |
| 42D  | 1345 | 1257  | 1194 | 36-1 1/2DUNC | Φ41 |
| 44D  | 1405 | 1314  | 1245 | 40-1 1/2DUNC | Φ41 |
| 48D  | 1510 | 1422  | 1359 | 44-1 1/2DUNC | Φ41 |
| 52D  | 1625 | 1537  | 1461 | 44-1 3/4DUNC | Φ47 |
| 56D  | 1745 | 1651  | 1575 | 48-1 3/4DUNC | Φ47 |
| 60D  | 1855 | 1759  | 1676 | 52-1 3/4DUNC | Φ47 |

## Flange and connection details

### JIS B2239-2004 10K

| DN   | D1   | n° | M    | T  | ●      | ⊕ | +  |
|------|------|----|------|----|--------|---|----|
| 50   | 120  | 4  | M-16 | 10 | 2--0   |   | -2 |
| 65   | 140  | 4  | M-16 | 10 | 2--0   |   | -2 |
| 80   | 150  | 8  | M-16 | 12 | 2--4   |   | -2 |
| 100  | 175  | 8  | M-16 | 12 | 2--4   |   | -2 |
| 125  | 210  | 8  | M-20 | 14 | 2--4   |   | -2 |
| 150  | 240  | 8  | M-20 | 14 | 2--4   |   | -2 |
| 200  | 290  | 12 | M-20 | 14 | 2--4   |   | -2 |
| 250  | 355  | 12 | M-22 | 18 | 4--6   |   | -2 |
| 300  | 400  | 16 | M-22 | 21 | 4--6   |   | -2 |
| 350  | 445  | 16 | M-22 | 21 | 6--8   |   | -2 |
| 400  | 510  | 16 | M-24 | 25 | 6--8   |   | -2 |
| 450  | 565  | 20 | M-24 | 25 | 8--10  |   | -2 |
| 500  | 620  | 20 | M-24 | 26 | 8--10  |   | -2 |
| 600  | 730  | 24 | M-30 | 26 | 8--10  |   | -2 |
| 700  | 840  | 24 | M-30 | 22 | 10--12 |   | -2 |
| 800  | 950  | 28 | M-30 | 22 | 10--12 |   | -2 |
| 900  | 1050 | 28 | M-30 | 22 | 12--12 |   | -4 |
| 1000 | 1160 | 28 | M-30 | 22 | 12--12 |   | -4 |
| 1200 | 1380 | 32 | M-36 | 33 | 14--14 |   | -4 |



DN50-65



DN80-150

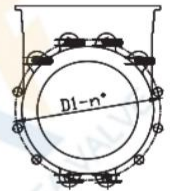

DN200-250



DN300-400



DN450-500

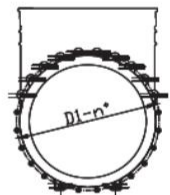

DN600-700

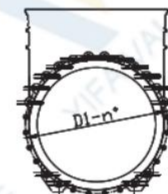

DN800-1000

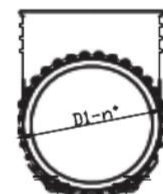

DN1200

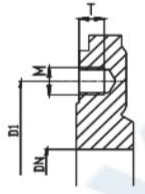

Blind hole tapping

- Blind hole thread
- ⊕ Through hole
- ⦿ Drilling through

### ANSI B16.5 & ASME B16.47 150Lb

| DN     | D1     | n° | M          | T  | ●      | ⊕ | +  |
|--------|--------|----|------------|----|--------|---|----|
| 2"     | 120.5  | 4  | 5/8" UNC   | 10 | 2--0   |   | -2 |
| 2 1/2" | 139.5  | 4  | 5/8" UNC   | 10 | 2--0   |   | -2 |
| 3"     | 152.5  | 4  | 5/8" UNC   | 12 | 2--4   |   | -2 |
| 4"     | 190.5  | 8  | 5/8" UNC   | 12 | 2--4   |   | -2 |
| 5"     | 216    | 8  | 3/4" UNC   | 14 | 2--4   |   | -2 |
| 6"     | 241.5  | 8  | 3/4" UNC   | 14 | 2--4   |   | -2 |
| 8"     | 298.5  | 8  | 3/4" UNC   | 14 | 2--4   |   | -2 |
| 10"    | 362    | 12 | 7/8" UNC   | 18 | 4--6   |   | -2 |
| 12"    | 432    | 12 | 7/8" UNC   | 21 | 4--6   |   | -2 |
| 14"    | 476    | 12 | 1" UNC     | 21 | 6--8   |   | -2 |
| 16"    | 540    | 16 | 1" UNC     | 25 | 6--8   |   | -2 |
| 18"    | 578    | 16 | 1 1/8" UNC | 25 | 8--10  |   | -2 |
| 20"    | 635    | 20 | 1 1/8" UNC | 26 | 8--10  |   | -2 |
| 24"    | 749.5  | 20 | 1 1/4" UNC | 26 | 8--10  |   | -2 |
| 28"    | 863.5  | 28 | 1 1/4" UNC | 26 | 10--12 |   | -2 |
| 30"    | 914    | 28 | 1 1/4" UNC | 22 | 10--12 |   | -2 |
| 32"    | 978    | 28 | 1 1/2" UNC | 22 | 12--12 |   | -4 |
| 36"    | 1085.8 | 32 | 1 1/2" UNC | 22 | 12--12 |   | -4 |
| 40"    | 1200.2 | 36 | 1 1/2" UNC | 30 | 14--14 |   | -4 |

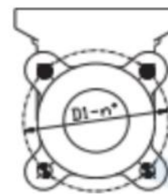

2"-3"



4"-8"

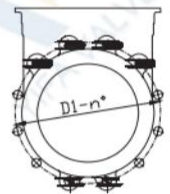

10"-14"

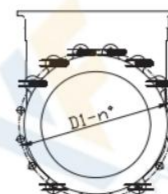

16"-18"



20"-24"

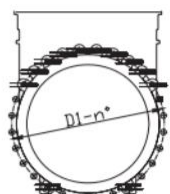

28"-32"

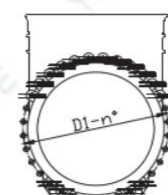

36"

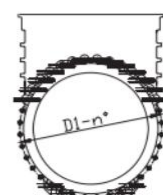

40"

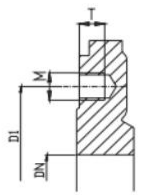

Blind hole tapping



#### ADDRESS

No.2 Road, Jinnan District  
Industrial Zone, Xiaozhan  
Town, Jinnan District, Tianjin,  
China



#### PHONE

0086 0379 69926196



#### EMAIL

[valve@yifavalves.com](mailto:valve@yifavalves.com)