

# YFZ45T GATE VALVE

## Product Description

YFZ45T non-rising stem metal seat gate valve is designed for reliable shut-of, high durability, and long service life indemanding industrial and water supply applications.

With a metal-to-metal sealing structure, the valve offers excellent resistance to wear, high temperature, and high-pressure conditions,ensuring stable performance even in harsh environments.The valve body is available in cast iron (GG25) or ductile iron (GGG50), with stainless steel or bronze sealing surfaces to enhancecorrosion resistance and extend service life.



### Technical Data

Size range	DN40-DN600
Pressure range	PN 10-16/Class 150/JIS10K
Temperature	- 10°C to 150 °C
Design	DIN3352,MSS SP-70,JISB2071
Face to face	DIN3202 F4,ANSI B16.10,JIS B2002
Connection	EN 1092-2,ANSI B16.5,JIS B2212/B2213
Coating	Electrostatic Powder Epoxy/Spray
Testing	API598
Medium	Water,oil,Gas

### Application Range

- HVAC Systems
- Pumping Stations
- Water Treatment Plants
- Reservoirs and Tanks
- Irrigation
- Industrial Applications

### Related Products

- YFZ44T MATEL SEAT GATE VALVE
- YFPZ73X KNIFE GATE VALVE
- YFH44X SWING CHECK VALVE



HVAC



IRRIGATION



POTABLE WATER



INDUSTRY

# YFZ45T

## GATE VALVE

### Product Description

---

#### 1. Durable Sealing for Harsh Conditions

Metal-to-metal sealing with stainless steel/bronze seats and wedges delivers superior wear, corrosion resistance and reliable shut-off, ideal for high-temperature, high-pressure or abrasive media.

#### 2. Space-Saving Installation

DIN F4 short face-to-face design plus non-rising stem fits tight spaces, including underground setups, minimizing pipeline layout constraints.

#### 3. High-Strength, Low-Maintenance Build

Made from GG25 cast iron or GGG50 ductile iron for exceptional mechanical strength, its robust structure cuts down maintenance frequency and long-term operational costs.

#### 4. Flexible Operation Options

Supports manual handwheel control or integration with electric, pneumatic or gearbox actuators for automated system compatibility.

#### 5. Broad Industry Application

Suitable for water supply, industrial pipelines, energy systems and general engineering projects, adapting to diverse sector needs.



# YFZ45T

## GATE VALVE

DIN3354-F4 PN10/16 DN40-DN300

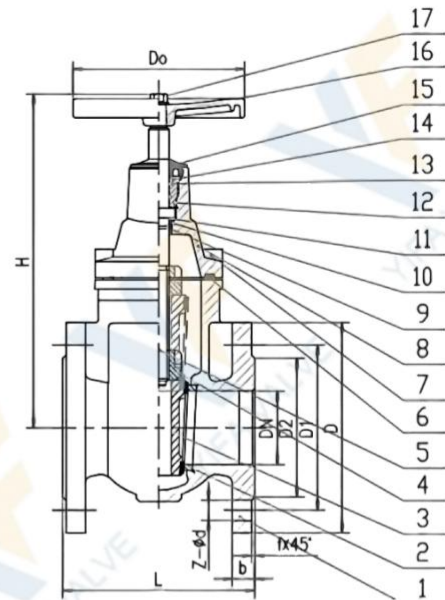

NO.	Name of parts	Material
1	Body	GG25/GGG50
2	Seat	Brass
3	Disc	GG25/GGG50
4	Stem Nut	Brass
5	Stem	2Cr13
6	Mid Gasket	GRAPH
7	Bonnet	GG25/GGG50
8	Rings	HPB59-1
9	O RING	EPDM
10	StemPacking	Graphite
11	Gland	GG25/GGG50

### Inspection Specification

PN	16
Seat test	1.76 Mpa
Shell test	2.4 Mpa
Temp:	-10-150°C
Medium	Water, Oil, Gas

DN	40	50	65	80	100	125	150	200	250	300
L	140	150	170	180	190	200	210	230	250	270
D	150	165	185	200	220	250	285	340	395	445
D1	110	125	145	160	180	210	240	295	350	400
D2	88	102	122	138	158	188	212	268	320	370
b	16	18			20		22	24	25	
H	235	258	288	340	350	395	458	550	648	690
f					S					4
Z-d		4-18			8-18		8-23		12-23	
Do		160			200		250		300	

# YFZ45T GATE VALVE

DIN3354-F4 PN10/16 DN50-DN600

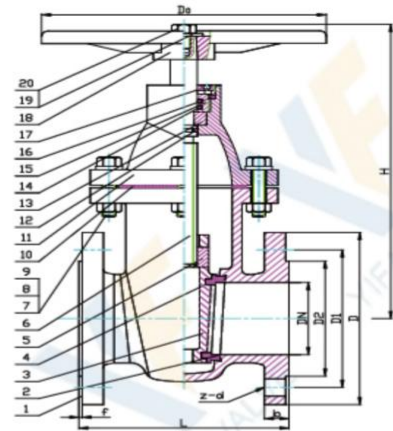

### Inspection Specification

PN	16
Seat test	1.76 Mpa
Shell test	2.4 Mpa
Temp:	-10-150°C
Medium	Water, Oil, Gas

NO.	Name of parts	Material
1	Body	GG25/GGG50
2	Seat	Brass
3	Disc	GG25/GGG50
4	Stem Nut	Brass
5	Stem	2Cr13
6	Mid Gasket	GRAPH
7	Bonnet	GG25/GGG50
8	Rings	HPB59-1
9	O RING	EPDM
10	StemPacking	Graphite
11	Gland	GG25/GGG50

DN	D	D1	D2	L	b	H	f	Z-d	D0
ø40	Ø150	Ø110	Ø84	140	18	214	3	4-18	Ø180
Ø50	Ø165	Ø125	Ø99	150	20	232	3	4-Ø18	φ200
ø65	Ø185	ø145	Ø118	170	20	258	3	4-18	φ200
ø80	φ200	Ø160	Ø132	180	22	281	3	8-Ø18	ø220
Ø100	φ220	φ180	ø156	190	24	315	3	8-Ø18	ø250
Ø125	φ250	φ210	Ø184	200	26	358	3	8-Ø18	φ280
Ø150	φ285	φ240	φ211	210	26	408	3	8-φ22	φ280
φ200	Ø340	φ295	φ266	230	30	500	3	12-Ø22	Ø320
φ250	Ø405	ø355	φ319	250	32	572	3	12-φ26	ø350
ø300	Ø460	ø410	ø370	270	32	662	4	12-φ26	ø400

# YFZ45T GATE VALVE

ANSI CLASS125 DN40-DN300

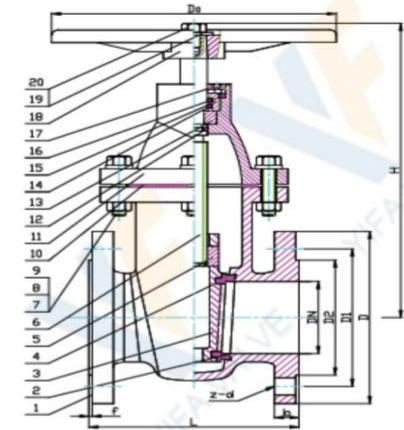

### Inspection Specification

PN	16
Seat test	1.76 Mpa
Shell test	2.4 Mpa
Temp:	-10-150°C
Medium	Water, Oil, Gas

NO.	Name of parts	Material
1	Body	GG25/GGG50
2	Seat	Brass
3	Disc	GG25/GGG50
4	Stem Nut	Brass
5	Stem	2Cr13
6	Mid Gasket	GRAPH
7	Bonnet	GG25/GGG50
8	Rings	HPB59-1
9	O RING	EPDM
10	StemPacking	Graphite
11	Gland	GG25/GGG50

DN	D	D1	L	b	H	Z-d
ø40	Ø127	Ø98.5	165	15	256	4-16
Ø50	ø152	ø120.5	178	16	274	4-Ø19
ø65	ø178	ø139.5	190	17.5	303	4-419
ø80	ø191	ø152.5	203	19	331	4-419
Ø100	ø229	ø190.5	229	24	368	8-Ø19
Ø125	Ø254	Ø216	254	24	416	8-φ22
Ø150	ø279	ø241.5	267	25.5	457	8-22
φ200	ø343	298.5	292	29	550	8-φ22
φ250	ø406	ø362	330	30.5	632	12-Ø25
ø300	ø483	ø432	356	32	711	12-Ø25
ø350	φ533	ø476	381	35	805	12-429
ø400	ø597	ø539.5	406	37	884	16-φ29

# YFZ45T GATE VALVE

JIS10K DN40-DN300

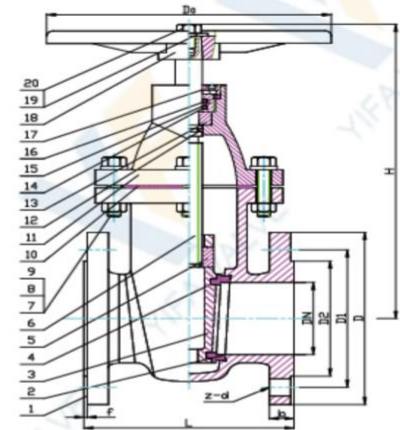

### Inspection Specification

PN	16
Seat test	1.76 Mpa
Shell test	2.4 Mpa
Temp:	-10-150°C
Medium	Water, Oil, Gas

NO.	Name of parts	Material
1	Body	GG25/GGG50
2	Seat	Brass
3	Disc	GG25/GGG50
4	Stem Nut	Brass
5	Stem	2Cr13
6	Mid Gasket	GRAPH
7	Bonnet	GG25/GGG50
8	Rings	HPB59-1
9	O RING	EPDM
10	StemPacking	Graphite
11	Gland	GG25/GGG50

DN	D	D1	L	b	H	Z-d
ø40	ø140	105	165	15	256	4-ø19
ø50	ø155	ø120	178	16	274	4-ø19
ø65	ø175	ø140	190	17.5	303	4-ø19
ø80	ø185	ø150	203	19	331	8-ø19
ø100	ø210	ø175	229	19	368	8-ø19
ø125	ø250	ø210	254	19	416	8-ø23
ø150	ø280	ø240	267	19	457	8-ø23
ø200	ø330	ø290	292	20	550	12-ø23
ø250	ø400	ø355	330	22	632	12-ø25
ø300	ø445	ø400	356	24.5	711	16-ø25

# YFZ45T

## GATE VALVE



### Valve operation

#### 1- MANUAL OPERATION

ALL GEARBOX MODELS ARE MADE OF DUCTILE CAST IRON WITH THE FOLLOWING FEATURES

- Stable Self-Locking Design.
- Superior Gear Contact Ratio.
- Changeable Bushing enables Gearbox installation in any position
- Visual position indicator



#### 2- PNEUMATIC OPERATION

PNEUMATIC ACTUATORS ARE USED FOR FAST AND FREQUENT OPENING AND CLOSING, WHERE THE VALVE PRESSURE IS LESS THAN 6 BAR AND THE VALVE SIZE IS NOT LARGER THAN DN 800 WHICH IS TYPICAL USED FOR WATER TREATMENT SYSTEM VALVES



#### 3- ELECTRIC OPERATION

ELECTRIC ACTUATORS PROVIDED ON OUR VALVES COVER A WIDER RANGE OF TORQUES. SOME OPTIONAL FEATURES FOR ELECTRIC ACTUATORS



# YFZ45T

## GATE VALVE



### Installation

---

#### 1. Pre-Installation Inspection

Verify valve specifications (size, pressure rating, material, and standard DIN F4). Inspect the valve for any damage during transportation, especially sealing surfaces and flange faces. Ensure the valve is in the slightly open position before installation to protect the sealing surfaces. Remove all protective covers and clean internal passages.

#### 2. Pipeline Preparation

Thoroughly clean the pipeline to remove welding slag, rust, sand, or other foreign materials. Ensure flange faces are flat, aligned, and free from damage. Confirm proper pipeline support to avoid external stress on the valve body.

#### 3. Installation Position

The valve can be installed in horizontal or vertical pipelines. Recommended position: stem vertically upward for optimal operation and reduced wear. Avoid installation in positions with strong vibration or heavy external loads.

#### 4. Flow Direction

Gate valves are generally bi-directional, but it is recommended to follow the indicated flow direction (if marked) for optimal performance. Ensure correct orientation to minimize turbulence and wear.

#### 5. Flange Connection

Use appropriate gaskets suitable for working conditions (temperature, pressure). Tighten bolts evenly in a cross (diagonal) pattern. Avoid over-tightening, which may damage flange surfaces or cause deformation.

#### 6. Operation Check After Installation

Open and close the valve slowly to ensure smooth operation. Check for abnormal resistance, noise, or vibration. Verify there is no leakage at flange connections.

#### 7. Pressure Testing

Perform system pressure testing according to applicable standards. Increase pressure gradually to avoid sudden impact. Check sealing performance under working condition.

# YFZ45T

## GATE VALVE

### Precautions / Important Notes

#### 1. Do Not Over-Tighten (Critical for Metal Seat)

Unlike soft seat valves, excessive closing force may damage the sealing surfaces.

#### 2. Not Suitable for Frequent Throttling

Gate valves are designed for fully open or fully closed operation, not for flow regulation.

#### 3. Protect Sealing Surfaces from Damage

Foreign particles may scratch metal sealing surfaces and affect sealing performance.

#### 4. Regular Operation Recommended

Operate the valve periodically to prevent sticking, especially in long-term idle systems.

#### 5. Avoid Misalignment During Installation

Improper alignment may cause stress on the valve body and reduce service life.

#### 6. Maintenance Under No Pressure Only

Always release system pressure before performing any maintenance or disassembly.

#### 1. Pre-Installation Inspection

Check valve specs & ensure slightly OPEN position.



Slightly Open

#### 2. Pipeline Preparation

CLEAN pipeline thoroughly, confirm flange alignment.



Clean & Aligned ✓

#### 3. Correct Installation

Install STEM VERTICALLY UPWARD, avoid strong vibrations.

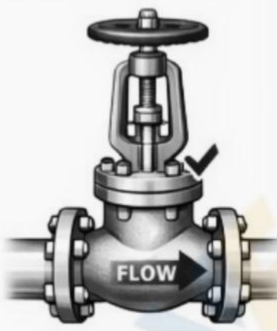

Proper Installation

#### 4. Flow Direction

Follow FLOW DIRECTION arrow (if marked).

#### 5. Cross Pattern

Tighten bolts in a CROSS PATTERN, avoid excessive force.



OPEN / CLOSE →

#### 5. Flange Connection

Tighten bolts in a CROSS PATTERN, avoid excessive force.

#### 6. Operation & Testing

OPEN / CLOSE slowly, avoid over-tightening, perform pressure testing.



**CAUTION:** Unlike soft seat valves, EXCESSIVE FORCE MAY DAMAGE METAL SEALING SURFACES. Avoid over-tightening when closing the valve.

## Material Table-Metal

PARTS	ASME	DIN/EN	Cr	Ni	Mo	Ti	Temp.Range
	A216 WCB	GS-20 Mn 5	0.5	0.5	0.2	-	-29~425
	A216WCC	G20Mn5	0.5	0.5	0.2	-	-29~425
	A217 WC1		0.35	0.5	0.45~0.65		≤455
	A217 WC5		0.5~0.9	0.6~1	0.9~1.2	-	≤565
	A217 WC6	GS 17CrMo55	1~1.5		0.45~0.65		≤595
	A217 WC9		2~2.75	-	0.9~1.2	-	≤595
	A217 C5		4~6.5		0.45~0.65	-	≤650
	A217 C12		8~10	-	0.9~1.2	-	≤650
	A296 CA15	1.4006,1.4008	11.5~14	1	0.5	-	-20~480
	A351 CF8	G-X5CrNi <sup>18</sup> -10	18~21	8~11	0.05	-	≤458(540)
	A351 CF8M	X5CrNiMo18-10	18~21	9~13	2~3	-	≤425(540)
	A351 CF3	X2CrNiMo18-10	17~21	8~12	0.5	-	≤425
	A351 CF3M	GX10CrNiMo18-9	17~21	9~13	2~3		≤455
Casting	Aisi 321	X10CrNiTi18-9,1.4541	17~19	9~12	-	0.5	≤700/540
	Aisi904L	X1NiCrMoCuN25-20-6,1.4539	19~21	24~26	-		-165~600
	Aisi 316Ti	X6CrNiMoTi17-12-2	16~18	10~14	-	0.7	-165~600
	Aisi 310S	X8CrNi25-21,1.4845	24~26	19~22	-	-	≤850
	A352 LCB		-	-	-	-	-46~345
	A352 LCC		-	-	-	-	-46~345
	A352 LC1	G20Mo5,1.5419	-	-	-	-	-59~345
	A352 LC2			2~3	-		-73~200
	A352 LC3		-	3~4	-	-	-101~200
	A105(N)	C21,1.0432,S+35.8	0.3	0.4	0.12		≤450
	A350 LF1		-	-	-	-	-46~425
	A350 LF2			-			-60
	A350 LF3	10Ni14,1.5637	-	3.25~3.75	-		-101~345
	A516 Gr70	1.0539,1.0545			-	-	-46~425

## Material Table-Metal

PARTS	ASME	DIN/EN	Cr	Ni	Mo	Ti	Temp.Range
Forging	A 182 F304	174,401.4301	18~20	8~11	-	-	≤800/540
	A 182 F321	X10CrNiTi18-9,1.4541	17~21	9~12	-	0.7	≤800/540
	A 182 F316	174,401.4401	16~18	10~14	2~3	-	800/540
	A 182 F316L	174,401.4404	16~18	10~15	2~3	-	≤450
	A 182 F304L	174,401.4306	18~20	8~13	-	-	≤425
	A 182F310		24~26	19~22			-29~800
	Duplex2205	X2CrNiMoN22-5-3,1.4462	21~24	4.5~6.5	2.5~3.5	-	≤450
	Duplex2304	X2CrNiN23-4,1.4362	21.5~24.5	3~5.5	0.05~0.6	-	≤425
	Duplex2507	X2CrNiMoN25-7-4,1.4410	24~26	6~8	3~5	-	-40~315
	A 182 F51	X2 CrNiMoN 22-5-3,1.4462	21~23	4.5~6.5	2.5~3.5	-	-40~315
	A 182 F1	1.5Mo3,1.5415	-	-	0.44~0.65	-	≤470
	A 182 F2	1.7335,1.7337	0.5~0.81	-	0.44~0.65	-	≤540
	A 182 F11	13CrMo4-4,1.7335	1~1.5	-	0.44~0.65	-	≤545
	A 182F22	10CrMo9-10,1.7380		0.87~1.13		-	≤550
	A 182 F12	13CrMo4-5,1.7335	0.8~1.25	-	0.44~0.65	-	≤545
	A 182 F9	X12CrMo 9-1,1.7386	8~10	-	0.9~1.1	-	≤673
	A 182 F91	1.4903,1.7332	8~9.5	0.4	0.85~1.05	-	≤673
	A 182 F5		4~6.5	0.5	0.44~0.65	-	≤550
	A 182F6a	X10Cr13	11.5~13.5	0.5	-	-	-101~480
	A 182 F44	X1CRNiMoCuN20-18-7,1.4547	19.5~20.5	17.5~18.5	6~6.5	-	≤540
Rod	Aisi 410	X12CrN13,1.4006	11.5~13.5	0.6	-	-	-38~350
	Aisi 416	X20Cr13	12~14	-	-	-	-101~480
	Aisi 420	X20Cr13	12~14	-	-	-	-101~480
	Aisi 430	X6Cr17	16~18	-	-	-	-38~425
	Aisi431	Z15CN16-02,1.4057	16~18	1.5~2.5	-	0.2	-38~425
	A276 XM-19	GX4CrNiMnN22-12-5,1.3964	20.5~23.5	11.5~13.5	1.5~3		≤550
	A 193 B7		0.75~1.2		0.15~0.25		-45.6~510
	A 193 B7M		0.75~1.2		0.15~0.25	-	-20~510
	A 193 B16		0.8~1.15	-	0.5~0.65	-	-10~600
	A320 L7		0.8~1	-	0.15~0.25	-	-101~550
	A320 B8		18~20	8~10.5	-	-	254~700
	A320 B8A		18~20	8~10.5	-	-	254~700
	A320 B8M		16~18	10~14	-	-	254~816
A320 B8T		17~19	9~12	2~3	-	196~700	
Fasteners	A 1942H		-	-	-	-	-38~450
	A 1946		11.5~13.5	-		-	-101~480
	A 1948,8A		8~10.5	18~20	-		-254~800
	A 1948M,8MA		16~18	10~14	2~3	-	-254~816
	A 1948T,8TA		17~19	9~12	-		0.3~0.6 -196~700
	D507Mo		10~16	6	2.5	-	≤450
	Alloy 20		19~21	32~38	2~3	-	≤427
	Alloy 904L		19~23	23~28	4~5	-	≤700
Surfacing welding	Uranus B-6		20.5	25.5	4.5	-	≤700
	Lewmet 25		29	-	4.5	-	≤700
	Stellite Alloy 6		27~32	3	1	-	≤700
	Inconel Alloy 625		20~23	58	8~10	0.4	≤700
	Hastelloy AlloyC-276		15.5	-	16	-	≤700

## Seal parts

Parts	Characteristic	Low/High Temperature		Recommended
NR	High elasticity	-20	85	-5~70
NBR	Oil resistivity	-30	100	-15~90
EPDM	Aging resistance, ozone resistance, corrosion resistance	-40	125	-25~110
HT EPDM	Same as above, added heat resistance	-40	150	-25~135
SBR (wear-resistant)	Excellent traction performance and wear resistance	-30	100	-15~80
CR (neoprene)	Oil, heat, flame, sunlight, ozone, acid and alkali resistance	-30	125	-15~100
Hypalon	Oxidation resistance, resistance to winding and cracking	-40	120	-25~110
FPM (viton)	Chemical and most oils resistance, (except ketones & esters)	-20	200	-5~150
MVQ (silicon)	High and low temperature resistance, oil, corrosion resistance	-55	200	-30~180
PU	Chemical, oil, wear, low temperature, aging resistance	-20	120	-5~90
FEP (F46)	Chemical resistance, radiation resistance	-20	150	-5~120
PTFE	Heat, cold, acid, alkali, organic solvents resistant	-60	180	-45~150
RPTFE	Corrosion resistance, low friction coefficient	-60	180	-45~150
PFA	Excellent chemical corrosion resistance, low friction coefficient	-196	200	-60~180
PPL	High temperature and chemical corrosion resistance	-60	230	-45~200
UPVC	Corrosion and pressure resistance, hygiene	-30	100	-15~80
CPVC	Corrosion and pressure resistance, hygiene	-30	110	-15~95
PVDF	Anti aging and chemical resistance	-30	100	-15~70
PEEK	High temperature and chemical resistance	-60	300	-45~260
Flexible graphite	Cold and hot resistant, corrosion resistant, self-lubricating	-200	600	-60~550
Ceramic fiber	Fire, high temperature resistance, low thermal conductivity	-200	1050	-60~950
Metal to metal	High temperature, high pressure, wear, corrosion resistance	Refer to the material		

Unit: Degree

## Inspection Standards and Requirements

Inspection Standards and Requirements							
		ISO5208:2008 / GB/T13927			API598-2004		
Shell strength	Medium temperature	5~40			5~40		
	Medium	Water, kerosene, air, suitable gas			Water, kerosene, air, suitable gas		
	Test pressure	Norminal pressure (PN)×1.5			Norminal pressure×1.5		
	Minimum duration of the test	DN	Seconds		NPS	Check valve	Others
		≤50	15		≤2"	60	15
		65~200	60		2½"~6"	60	60
≥250		180		8"~12"	60	120	
Assessment	No visible leakage allowed			No visible leakage allowed			
Back seal	Test pressure	DN	PN	Pressure	NPS	Class	Pressure
		≤80	All	0.6Mpa	All	≤300	0.4~0.7Mpa
		100~200	≤5.0	0.6Mpa			
		100~200	>5.0	PN × 1.1		>300	Class x 1.1
	≥250	All	PN × 1.1				
Assessment	No visible leakage allowed			No visible leakage allowed			
High pressure sealing test	Test pressure	DN	PN	Pressure	Class	Ductile iron	Steel
		≤80	All	PN × 1.1 (liquid)	150	1.7 Mpa	Class x 1.1
		100~200	≤5.0	0.5~0.7Mpa (air)			
		100~200	>5.0	PN × 1.1 (liquid)	300	4.4 Mpa	
		≥250	All	0.5~0.7Mpa (air)			
		Minimum duration of the test	DN	Metal seal	Resilient seal	NPS	Check valve
	≤50	15	15	≤2"	60	15	
	65~200	30	15	2½"~6"	60	60	
	250~450	60	30	8"~12"	60	120	
	≥500	120	60	≥14"	120	120	
	Assessment	Class (level)	Liquid leakage	Air leakage	NPS	Liquid & Air	Liquid & Air
		A	No visible leakage allowed (mm <sup>3</sup> /s)		≤2"	Liquid:3cm <sup>3</sup> /in. min Air:0.042m <sup>3</sup> /in.h	0 drop(bubble)/min
		B	DN x 0.01	DN x 0.3	2½"~6"		12 & 24
		C	DN x 0.03	DN x 3	8"~12"		20 & 40
	D	DN x 0.1	DN x 30	≥14"		2 & 4 / in ·min	
	Low pressure sealing test	Medium	Air, suitable gas			Air, suitable gas	
Test pressure		0.5~0.7 Mpa			0.4~0.7 Mpa		
		DN	Metal seal	Resilient seal	NPS	Check valve	Others
		≤50	15	15	≤2"	60	15
Minimum duration of the test		65~200	30	15	2½"~6"	60	60
		250~450	60	30	8"~12"	60	120
		≥500	120	60	≥14"	120	120
Assessment		Class (level)	Air leakage		NPS	Air leakage	
		A	No visible leakage allowed (mm <sup>3</sup> /s)		≤2"		0 bubble /min
		B	DN x 0.3		2½"~6"	0.042 m <sup>3</sup> /in ·h	24
	C	DN x 3		8"~12"		40	
D	DN x 30		≥14"		4 / in ·min		

## Flange connection dimensions

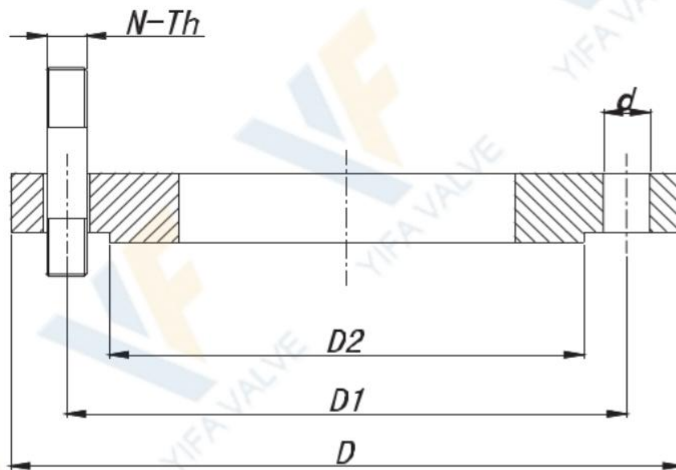

- D- Flange outer diameter
- D1- Bolt circle diameter
- D2- Diameter of sealing surface
- N-Th Bolt size
- d- Bolt hole diameter

### PN10 (DIN2632)

DN	D	D1	D2	N-Th	d
DN	D	D1	D2	N-Th	d
50	165	125	102	4-M16	Φ18
65	185	145	122	4-M16	Φ18
80	200	160	138	8-M16	Φ18
100	220	180	158	8-M16	Φ18
125	250	210	188	8-M16	Φ18
150	285	240	212	8-M20	Φ23
200	340	295	268	12-M20	Φ23
250	405	355	320	12-M24	Φ27
300	460	410	378	12-M24	Φ27
350	520	470	438	16-M24	Φ27
400	580	525	490	16-M27	Φ30
450	640	585	550	20-M27	Φ30
500	715	650	610	20-M30	Φ33
600	840	770	725	20-M33	Φ36
700	910	840	795	24-M33	Φ36
800	1025	950	900	24-M36	Φ39
900	1125	1050	1000	28-M36	Φ39
1000	1255	1170	1115	28-M39	Φ42
1200	1485	1390	1330	32-M45	Φ48
1400	1685	1590	1530	36-M45	Φ48
1600	1930	1820	1750	40-M52	Φ56
1800	2130	2020	1950	44-M52	Φ56
2000	2345	2230	2150	48-M56	Φ62

### PN16 (DIN2632)

DN	D	D1	D2	N-Th	d
DN	D	D1	D2	N-Th	d
50	165	125	102	4-M16	Φ18
65	185	145	122	4-M16	Φ18
80	200	160	138	8-M16	Φ18
100	220	180	158	8-M16	Φ18
125	250	210	188	8-M16	Φ18
150	285	240	212	8-M20	Φ23
200	340	295	268	12-M20	Φ23
250	405	355	320	12-M24	Φ27
300	460	410	378	12-M24	Φ27
350	520	470	438	16-M24	Φ27
400	580	525	490	16-M27	Φ30
450	640	585	550	20-M27	Φ30
500	715	650	610	20-M30	Φ33
600	840	770	725	20-M33	Φ36
700	910	840	795	24-M33	Φ36
800	1025	950	900	24-M36	Φ39
900	1125	1050	1000	28-M36	Φ39
1000	1255	1170	1115	28-M39	Φ42
1200	1485	1390	1330	32-M45	Φ48
1400	1685	1590	1530	36-M45	Φ48
1600	1930	1820	1750	40-M52	Φ56
1800	2130	2020	1950	44-M52	Φ56
2000	2345	2230	2150	48-M56	Φ62

## Flange connection dimensions

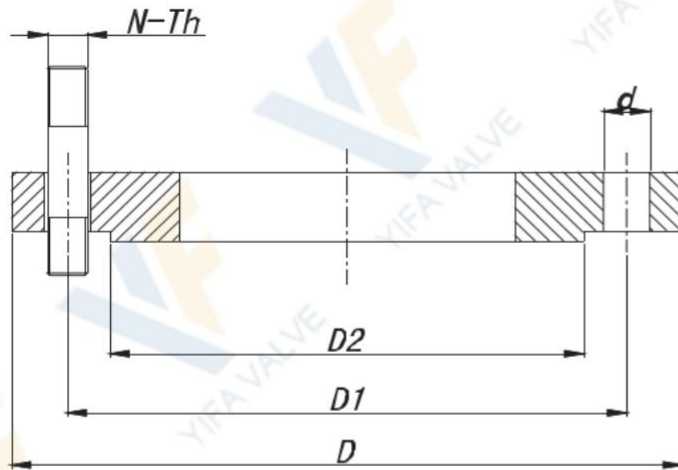

- D- Flange outer diameter
- D1- Bolt circle diameter
- D2- Diameter of sealing surface
- N-Th Bolt size
- d- Bolt hole diameter

### PN10 (GB/T9113.1)

DN	D	D1	D2	N-Th	d
50	165	125	99	4-M16	Φ18
65	185	145	118	4-M16	Φ18
80	200	160	132	8-M16	Φ18
100	220	180	156	8-M16	Φ18
125	250	210	184	8-M16	Φ18
150	285	240	211	8-M20	Φ23
200	340	295	266	8-M20	Φ23
250	395	350	319	12-M20	Φ23
300	445	400	370	12-M20	Φ23
350	505	460	429	16-M20	Φ23
400	565	515	480	16-M24	Φ27
450	615	565	530	20-M24	Φ27
500	670	620	582	20-M24	Φ27
600	780	725	682	20-M27	Φ30
700	895	840	794	24-M27	Φ30
800	1015	950	901	24-M30	Φ33
900	1115	1050	1001	28-M30	Φ33
1000	1230	1160	1112	28-M33	Φ36
1200	1455	1380	1328	32-M36	Φ39

### PN16 (GB/T9113.1)

DN	D	D1	D2	N-Th	d
50	165	125	99	4-M16	Φ18
65	185	145	118	4-M16	Φ18
80	200	160	132	8-M16	Φ18
100	220	180	156	8-M16	Φ18
125	250	210	184	8-M16	Φ18
150	285	240	211	8-M20	Φ23
200	340	295	266	12-M20	Φ23
250	405	355	319	12-M24	Φ27
300	460	410	370	12-M24	Φ27
350	520	470	429	16-M24	Φ27
400	580	525	480	16-M27	Φ30
450	640	585	548	20-M27	Φ30
500	715	650	609	20-M30	Φ33
600	840	770	720	20-M33	Φ36
700	910	840	794	24-M33	Φ36
800	1025	950	901	24-M36	Φ39
900	1125	1050	1001	28-M36	Φ39
1000	1255	1170	1112	28-M39	Φ42
1200	1485	1390	1328	32-M45	Φ48

## Flange and connection details

### GB/T9113.1 PN10

DN	D1	n°	M	T	●	⊕	+
50	125	4	M-16	10	2--0		-2
65	145	4	M-16	10	2--0		-2
80	160	8	M-16	12	2--4		-2
100	180	8	M-16	12	2--4		-2
125	210	8	M-16	14	2--4		-2
150	240	8	M-20	14	2--4		-2
200	295	8	M-20	14	2--4		-2
250	350	12	M-20	18	4--6		-2
300	400	12	M-20	21	4--6		-2
350	460	16	M-20	21	6--8		-2
400	515	16	M-24	25	6--8		-2
450	565	20	M-24	25	8--10		-2
500	620	20	M-24	26	8--10		-2
600	725	20	M-27	26	8--10		-2
700	840	24	M-27	22	10--12		-2
800	950	24	M-30	22	10--12		-2
900	1050	28	M-30	22	12--12		-4
1000	1160	28	M-33	22	12--12		-4
1200	1380	32	M-36	33	14--14		-4

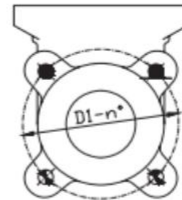

DN50-65

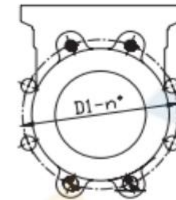

DN80-200

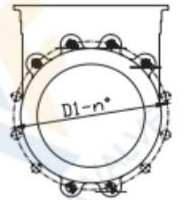

DN250-300



DN350-400



DN450-600

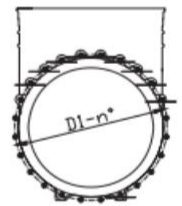

DN700-800

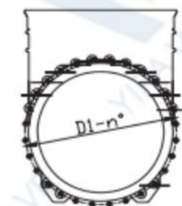

DN900-1000

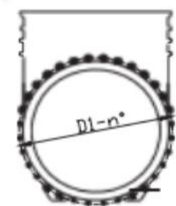

DN1200

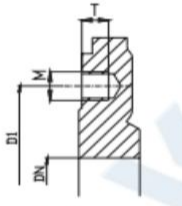

Blind hole tapping

- Blind hole thread
- ⊕ Through hole
- Drilling through

### GB/T9113.1 PN16

DN	D1	n°	M	T	●	⊕	+
50	125	4	M-16	10	2--0		-2
65	145	4	M-16	10	2--0		-2
80	160	8	M-16	12	2--4		-2
100	180	8	M-16	12	2--4		-2
125	210	8	M-16	14	2--4		-2
150	240	8	M-20	14	2--4		-2
200	295	12	M-20	14	2--4		-2
250	355	12	M-24	18	4--6		-2
300	410	12	M-24	21	4--6		-2
350	470	16	M-24	21	6--8		-2
400	525	16	M-27	25	6--8		-2
450	585	20	M-27	25	8--10		-2
500	640	20	M-30	26	8--10		-2
600	725	20	M-33	26	8--10		-2
700	840	24	M-33	22	10--12		-2
800	950	24	M-36	22	10--12		-2
900	1050	28	M-36	22	12--12		-4
1000	1170	28	M-39	22	12--12		-4
1200	1390	32	M-45	33	14--14		-4

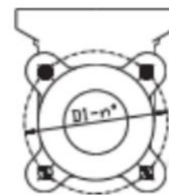

DN50-65



DN80-150

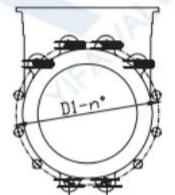

DN200-300



DN350-400



DN450-600

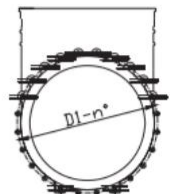

DN700-800

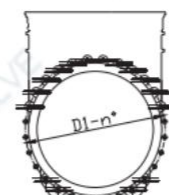

DN900-1000

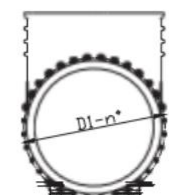

DN1200

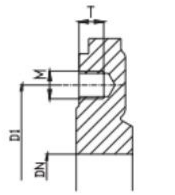

Blind hole tapping

## Flange connection dimensions

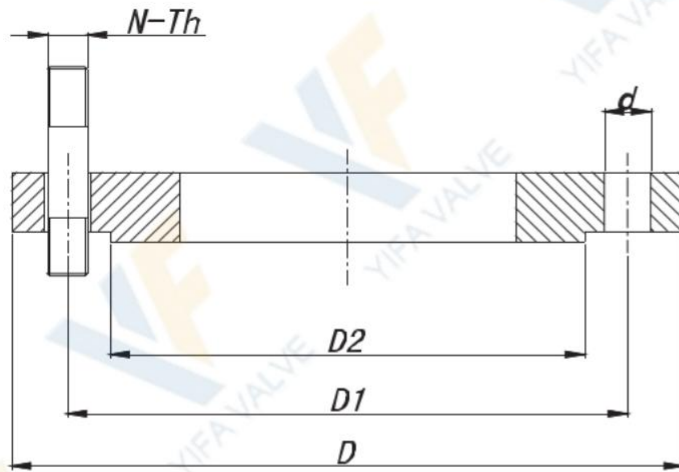

- D- Flange outer diameter
- D1- Bolt circle diameter
- D2- Diameter of sealing surface
- N-Th Bolt size
- d- Bolt hole diameter

10K (JIS B2239-2004)

150Lb (ANSI B16.5 & ASME B16.47)

DN	D	D1	D2	N-Th	d
50	155	120	96	4-M16	Φ19
65	175	140	116	4-M16	Φ19
80	185	150	126	8-M16	Φ19
100	210	175	151	8-M16	Φ19
125	250	210	182	8-M20	Φ23
150	280	240	212	8-M20	Φ23
200	330	290	262	12-M20	Φ23
250	400	355	324	12-M22	Φ25
300	445	400	368	16-M22	Φ25
350	490	445	413	16-M22	Φ25
400	560	510	475	16-M24	Φ27
450	620	565	530	20-M24	Φ27
500	675	620	585	20-M24	Φ27
550	745	680	640	20-M30	Φ33
600	795	730	690	24-M30	Φ33
650	845	780	740	24-M30	Φ33
700	905	840	800	24-M30	Φ33
750	970	900	855	24-M30	Φ33
800	1020	950	905	28-M30	Φ33
850	1070	1000	955	28-M30	Φ33
900	1120	1050	1005	28-M30	Φ33
1000	1235	1160	1110	28-M36	Φ39
1100	1345	1270	1220	28-M36	Φ39
1200	1465	1380	1325	32-M36	Φ39
1350	1630	1540	1480	36-M42	Φ45
1500	1795	1700	1635	40-M42	Φ45

DN	D	D1	D2	N-Th	d
2D	153	120.5	92	4-5/8DUNC	Φ19
2.5D	178	139.5	105	4-5/8DUNC	Φ19
3D	191	152.5	127	4-5/8DUNC	Φ19
4D	229	190.5	157	8-5/8DUNC	Φ19
5D	254	216	186	8-3/4DUNC	Φ22
6D	280	241.5	216	8-3/4DUNC	Φ22
8D	343	298.5	270	8-3/4DUNC	Φ22
10D	407	362	324	12-7/8DUNC	Φ25
12D	483	432	381	12-7/8DUNC	Φ25
14D	534	476	413	12-1DUNC	Φ29
16D	597	539.5	470	16-1DUNC	Φ29
18D	635	578	534	16-1 1/8DUNC	Φ32
20D	699	635	584	20-1 1/8DUNC	Φ32
24D	813	749.5	692	20-1 1/4DUNC	Φ35
26D	870	806.5	749	24-1 1/4DUNC	Φ35
28D	925	863.5	800	28-1 1/4DUNC	Φ35
30D	985	914.5	857	28-1 1/4DUNC	Φ35
32D	1060	978	914	28-1 1/2DUNC	Φ41
36D	1170	1086	1022	32-1 1/2DUNC	Φ41
40D	1290	1200	1124	36-1 1/2DUNC	Φ41
42D	1345	1257	1194	36-1 1/2DUNC	Φ41
44D	1405	1314	1245	40-1 1/2DUNC	Φ41
48D	1510	1422	1359	44-1 1/2DUNC	Φ41
52D	1625	1537	1461	44-1 3/4DUNC	Φ47
56D	1745	1651	1575	48-1 3/4DUNC	Φ47
60D	1855	1759	1676	52-1 3/4DUNC	Φ47

## Flange and connection details

### JIS B2239-2004 10K

DN	D1	n°	M	T	●	⊕	+
50	120	4	M-16	10	2--0		-2
65	140	4	M-16	10	2--0		-2
80	150	8	M-16	12	2--4		-2
100	175	8	M-16	12	2--4		-2
125	210	8	M-20	14	2--4		-2
150	240	8	M-20	14	2--4		-2
200	290	12	M-20	14	2--4		-2
250	355	12	M-22	18	4--6		-2
300	400	16	M-22	21	4--6		-2
350	445	16	M-22	21	6--8		-2
400	510	16	M-24	25	6--8		-2
450	565	20	M-24	25	8--10		-2
500	620	20	M-24	26	8--10		-2
600	730	24	M-30	26	8--10		-2
700	840	24	M-30	22	10--12		-2
800	950	28	M-30	22	10--12		-2
900	1050	28	M-30	22	12--12		-4
1000	1160	28	M-30	22	12--12		-4
1200	1380	32	M-36	33	14--14		-4

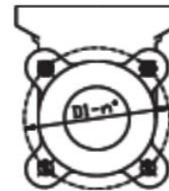

DN50-65



DN80-150

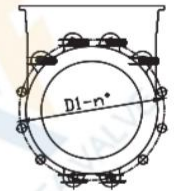

DN200-250

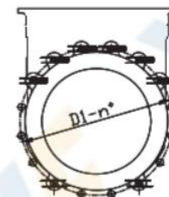

DN300-400



DN450-500

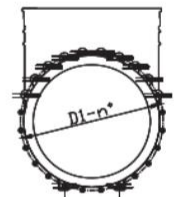

DN600-700

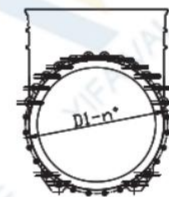

DN800-1000

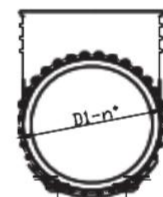

DN1200

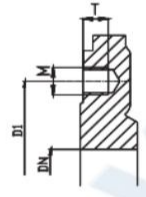

Blind hole tapping

- Blind hole thread
- ⊕ Through hole
- ⦿ Drilling through

### ANSI B16.5 & ASME B16.47 150Lb

DN	D1	n°	M	T	●	⊕	+
2"	120.5	4	5/8" UNC	10	2--0		-2
2 1/2"	139.5	4	5/8" UNC	10	2--0		-2
3"	152.5	4	5/8" UNC	12	2--4		-2
4"	190.5	8	5/8" UNC	12	2--4		-2
5"	216	8	3/4" UNC	14	2--4		-2
6"	241.5	8	3/4" UNC	14	2--4		-2
8"	298.5	8	3/4" UNC	14	2--4		-2
10"	362	12	7/8" UNC	18	4--6		-2
12"	432	12	7/8" UNC	21	4--6		-2
14"	476	12	1" UNC	21	6--8		-2
16"	540	16	1" UNC	25	6--8		-2
18"	578	16	1 1/8" UNC	25	8--10		-2
20"	635	20	1 1/8" UNC	26	8--10		-2
24"	749.5	20	1 1/4" UNC	26	8--10		-2
28"	863.5	28	1 1/4" UNC	26	10--12		-2
30"	914	28	1 1/4" UNC	22	10--12		-2
32"	978	28	1 1/2" UNC	22	12--12		-4
36"	1085.8	32	1 1/2" UNC	22	12--12		-4
40"	1200.2	36	1 1/2" UNC	30	14--14		-4

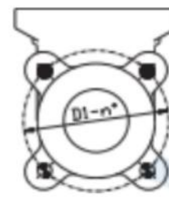

2"-3"



4"-8"

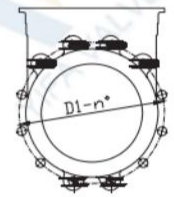

10"-14"

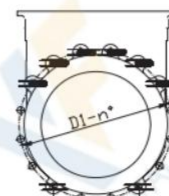

16"-18"

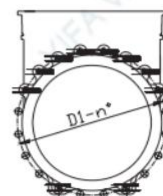

20"-24"

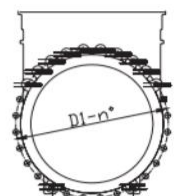

28"-32"

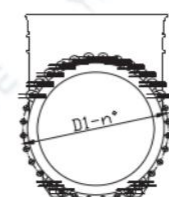

36"

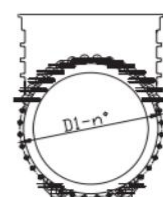

40"

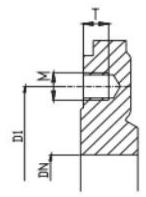

Blind hole tapping



#### ADDRESS

No.2 Road, Jinnan District  
Industrial Zone, Xiaozhan  
Town, Jinnan District, Tianjin,  
China



#### PHONE

0086 0379 69926196



#### EMAIL

[valve@yifavalves.com](mailto:valve@yifavalves.com)