

YFZ45X GATE VALVE

Product Description

YFZ45X non-rising stem resilient gate valve is designed for reliable sealing, smooth operation, and long-term durability in watersupply and pipeline systems.

Featuring a fully rubber-coated wedge, corrosion-resistant epoxy coating, and a non-rising stem structure, the valve ensures tightshut-off, low torque operation, and space-saving installation.

It is widely used in water treatment, municipalinfrastructure, fire protectionsystems, and general pipeline applications.



Technical Data

Size range	DN40-DN1600
Pressure range	PN 10-16/Class 150/JIS10K
Temperature	EPDM : -10°C to +100 °C NBR: - 10°C to + 80 °C
Design	EN1171, DIN3352, EN1074-1
Face to face	EN558-1 Series 14/15, DIN3202 F4/F5
Connection	EN 1092-2, ISO7005-2
Coating	Electrostatic Powder Epoxy
Testing	EN 12266, ISO5208
Medium	Water,oil,Gas

Application Range

- HVAC Systems
- Pumping Stations
- Water Treatment Plants
- Reservoirs and Tanks
- Irrigation
- Industrial Applications

Related Products

- YFZ44T MATEL SEAT GATE VALVE
- YFPZ73X KNIFE GATE VALVE
- YFH44X SWING CHECK VALVE



HVAC



IRRIGATION



POTABLEWATER



INDUSTRY

YFZ45X

GATE VALVE

Product Description

1. High-Strength, Corrosion-Resistant Body

Constructed from GGG40/50 ductile iron (2450 MPa tensile strength, >10% elongation) with full internal/external >250um epoxy coating, the valve boasts exceptional toughness, cracking resistance and long-term corrosion protection.

2. Zero-Leakage Sealing System

Fully EPDM-coated wedge (>50% rubber content) and resilient soft-seal design ensure bubble-tight shut-off, with reliable sealing that resists rubber detachment during long-term operation, ideal for water systems.

3. Space-Saving, Durable Stem Assembly

Non-rising stem design saves space for underground/confined installations; made from corrosion-resistant 2Cr13 stainless steel, it features triple O-ring sealing (enabling under-pressure replacement) and a brass nut for smooth, jam-free operation.

4. Low-Torque, Versatile Operation

Optimized internal structure minimizes friction, allowing effortless manual or actuator-controlled operation with low torque requirements.

5. Long Service Life & Minimal Maintenance

Premium materials, robust sealing and wear-resistant components combine to deliver an extended service life with significantly reduced maintenance needs.



YFZ45X

GATE VALVE

BS5163 PN10/16 DN40-DN1000

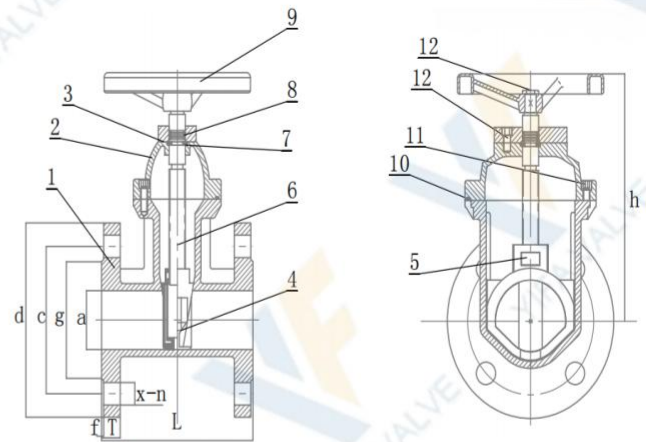

Inspection Specification

PN	16
Seat test	1.76 Mpa
Shell test	2.4 Mpa
Temp:	-10-120°C
Medium	Water, Oil, Gas

ITEM	Part Name	Material
1	Body	GGG50
2	Bonnet	GGG50
3	Sealing Ring	NBR
4	Disc	GGG50+EPDM
5	Stem Nut	BRASS
6	Stem	SS420
7	Holding Ring	BRASS
8	"O" Ring	Silica Gel
9	Handwheel	Carbon steel
10	Bonnet Gasket	EPDM
11	Bolt	Carbon Steel
12	Bolt	SS201

DN	L-mm	a-mm	d-mm		C-mm		x-n		T-mm	f-mm	g-mm
			PN10/PN16	PN10/PN16	10kg	16kg					
50	178	50	165	125	4-φ18		19	2	99		
65	190	65	185	145	4-φ18		19	2	118		
80	203	80	200	160	4-φ18	8-φ18	19	3	132		
100	229	100	220	180	8-φ18		19	3	156		
125	254	125	250	210	8-φ18		19	3	184		
150	267	150	285	240	8-φ23		19	3	211		
200	292	200	340	295	8-Ø23	12-Ø23	21	3	266		
250	330	250	395	350/355	12-φ23	12-φ26	22	3	319		
300	356	300	445	400/410	12-φ23	12-φ26	25	4	370		
350	381	350	515	460/470	16-Ø23	16-φ26	25	4	430		
400	406	400	580	515/525	16-φ26	16-φ31	28	4	475		
450	432	450	650	565/585	20-φ26	20-φ31	29	4	530		
500	457	500	670/715	620/650	20-Ø26	20-Ø34	29	4	580		
600	508	600	780/810	725/770	20-φ30	20-φ36	38	4	680		
800	660	800	1010/1025	950	24-Ø34	24-φ40	44	5	905		
900	711	900	1115/1125	1050	28-φ34	28-φ40	46	5	1001		
1000	811	1000	1230/1255	1160/1170	28-φ37	28-φ43	50	5	1112		

YFZ45X GATE VALVE

DIN3352 PN10/16 DN40-DN600

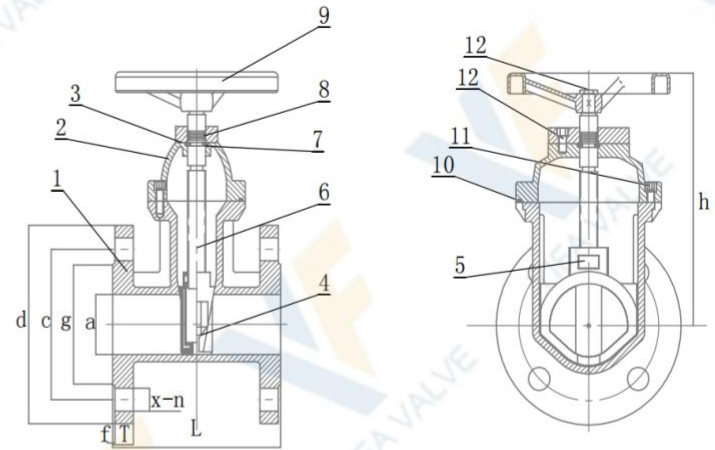

Inspection Specification

PN	16
Seat test	1.76 Mpa
Shell test	2.4 Mpa
Temp:	-10-120°C
Medium	Water, Oil, Gas

ITEM	Part Name	Material
1	Body	GGG50
2	Bonnet	GGG50
3	Sealing Ring	NBR
4	Disc	GGG50+EPDM
5	Stem Nut	BRASS
6	Stem	SS420
7	Holding Ring	BRASS
8	"O" Ring	Silica Qel
9	Handwheel	Carbon steel
10	Bonnet Gasket	EPDM
11	Bolt	Carbon Steel
12	Bolt	SS201

DN	L		h	a	d	c	x-n	+	f	g
	F5	F4								
40	240	150	240	40	150	110	4-Ø19	16	2	84
50	250	150	241	50	165	125	4-Ø19	16.5	2	99
65	270	170	270	65	185	145	4-Ø19	17	2	118
80	280	180	222	80	200	160	4-Ø19/8-Ø19	19	3	132
100	300	190	333	100	220	180	8-Ø19	20	3	156
125	325	200	384	125	250	210	8-Ø19	20	3	184
150	350	210	420	150	285	240	8-Ø23	20	3	211
200	400	230	512	200	340	295	8-Ø23/12-Ø23	20	3	266
250	450	250	602	250	405	350/355	12-Ø23/12-Ø26	25	3	319
300	500	270	705	300	460	400/410	12-Ø23/12-Ø26	28	4	370
350	550	290	782	350	520	460/470	16-Ø23/16-Ø26	28	4	430
400	600	310	880	400	582	515/525	16-Ø25/16-Ø30	28	4	475
450	650	330	1000	450	615/640	565/585	20-Ø26/20-Ø30	32	4	565/585
500	700	350	1055	500	670/715	620/650	20-Ø26/20-Ø30	32	4	580
600	800	390	1260	600	780/840	725/700	20-Ø30/20-Ø36	38	4	680

YFZ45X GATE VALVE



Valve operation

1- MANUAL OPERATION

ALL GEARBOX MODELS ARE MADE OF DUCTILE CAST IRON WITH THE FOLLOWING FEATURES

- Stable Self-Locking Design.
- Superior Gear Contact Ratio.
- Changeable Bushing enables Gearbox installation in any position
- Visual position indicator



2- PNEUMATIC OPERATION

PNEUMATIC ACTUATORS ARE USED FOR FAST AND FREQUENT OPENING AND CLOSING, WHERE THE VALVE PRESSURE IS LESS THAN 6 BAR AND THE VALVE SIZE IS NOT LARGER THAN DN 800 WHICH IS TYPICALLY USED FOR WATER TREATMENT SYSTEM VALVES



3- ELECTRIC OPERATION

ELECTRIC ACTUATORS PROVIDED ON OUR VALVES COVER A WIDER RANGE OF TORQUES. SOME OPTIONAL FEATURES FOR ELECTRIC ACTUATORS



YFZ45X

GATE VALVE



Installation

1. Pre-Installation Inspection

Verify valve specifications (size, pressure rating, material, and standard DIN F4). Inspect the valve for any damage during transportation, especially sealing surfaces and flange faces. Ensure the valve is in the slightly open position before installation to protect the sealing surfaces. Remove all protective covers and clean internal passages.

2. Pipeline Preparation

Thoroughly clean the pipeline to remove welding slag, rust, sand, or other foreign materials. Ensure flange faces are flat, aligned, and free from damage. Confirm proper pipeline support to avoid external stress on the valve body.

3. Installation Position

The valve can be installed in horizontal or vertical pipelines. Recommended position: stem vertically upward for optimal operation and reduced wear. Avoid installation in positions with strong vibration or heavy external loads.

4. Flow Direction

Gate valves are generally bi-directional, but it is recommended to follow the indicated flow direction (if marked) for optimal performance. Ensure correct orientation to minimize turbulence and wear.

5. Flange Connection

Use appropriate gaskets suitable for working conditions (temperature, pressure). Tighten bolts evenly in a cross (diagonal) pattern. Avoid over-tightening, which may damage flange surfaces or cause deformation.

6. Operation Check After Installation

Open and close the valve slowly to ensure smooth operation. Check for abnormal resistance, noise, or vibration. Verify there is no leakage at flange connections.

7. Pressure Testing

Perform system pressure testing according to applicable standards. Increase pressure gradually to avoid sudden impact. Check sealing performance under working condition.

YFZ45X

GATE VALVE

Precautions / Important Notes

1. Do Not Over-Tighten (Critical for Metal Seat)

Unlike soft seat valves, excessive closing force may damage the sealing surfaces.

2. Not Suitable for Frequent Throttling

Gate valves are designed for fully open or fully closed operation, not for flow regulation.

3. Protect Sealing Surfaces from Damage

Foreign particles may scratch metal sealing surfaces and affect sealing performance.

4. Regular Operation Recommended

Operate the valve periodically to prevent sticking, especially in long-term idle systems.

5. Avoid Misalignment During Installation

Improper alignment may cause stress on the valve body and reduce service life.

6. Maintenance Under No Pressure Only

Always release system pressure before performing any maintenance or disassembly.

1. Pre-Installation Inspection

Check valve specs & ensure slightly **OPEN** position.



Slightly Open

2. Pipeline Preparation

CLEAN pipeline thoroughly, confirm flange alignment.



Clean & Aligned ✓

3. Correct Installation

Install **STEM VERTICALLY UPWARD**, avoid strong vibrations.

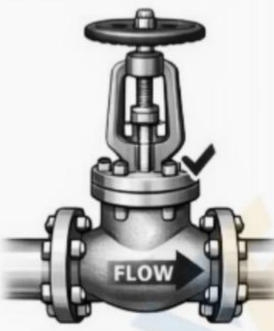

Proper Installation

4. Flow Direction

Follow **FLOW DIRECTION** arrow (if marked).

5. Cross Pattern

Tighten bolts in a **CROSS PATTERN**, avoid excessive force.



OPEN / CLOSE →

5. Flange Connection

Tighten bolts in a **CROSS PATTERN**, avoid excessive force.

6. Operation & Testing

OPEN / CLOSE slowly, avoid over-tightening, perform pressure testing.



CAUTION: Unlike soft seat valves, **EXCESSIVE FORCE MAY DAMAGE METAL SEALING SURFACES**. Avoid over-tightening when closing the valve.

Material Table-Metal

PARTS	ASME	DIN/EN	Cr	Ni	Mo	Ti	Temp.Range
A216 WCB		GS-20 Mn 5	0.5	0.5	0.2	-	-29~425
A216WCC		G20Mn5	0.5	0.5	0.2	-	-29~425
A217 WC1			0.35	0.5	0.45~0.65		≤455
A217 WC5			0.5~0.9	0.6~1	0.9~1.2	-	≤565
A217 WC6		GS 17CrMo55	1~1.5		0.45~0.65		≤595
A217 WC9			2~2.75	-	0.9~1.2	-	≤595
A217 C5			4~6.5		0.45~0.65	-	≤650
A217 C12			8~10	-	0.9~1.2	-	≤650
A296 CA15		1.4006,1.4008	11.5~14	1	0.5	-	-20~480
A351 CF8		G-X5CrNi ¹⁸ -10	18~21	8~11	0.05	-	≤458(540)
A351 CF8M		X5CrNiMo18-10	18~21	9~13	2~3	-	≤425(540)
A351 CF3		X2CrNiMo18-10	17~21	8~12	0.5	-	≤425
A351 CF3M		GX10CrNiMo18-9	17~21	9~13	2~3		≤455
Aisi 321		X10CrNiTi18-9,1.4541	17~19	9~12	-	0.5	≤700/540
Aisi904L		X1NiCrMoCuN25-20-6,1.4539	19~21	24~26	-		-165~600
Aisi 316Ti		X6CrNiMoTi17-12-2	16~18	10~14	-	0.7	-165~600
Aisi 310S		X8CrNi25-21,1.4845	24~26	19~22	-	-	≤850
A352 LCB			-	-	-	-	-46~345
A352 LCC			-	-	-	-	-46~345
A352 LC1		G20Mo5,1.5419	-	-	-	-	-59~345
A352 LC2				2~3	-		-73~200
A352 LC3			-	3~4	-	-	-101~200
A105(N)		C21,1.0432,S+35.8	0.3	0.4	0.12		≤450
A350 LF1			-	-	-	-	-46~425
A350 LF2				-			-60
A350 LF3		10Ni14,1.5637	-	3.25~3.75	-		-101~345
A516 Gr70		1.0539,1.0545			-	-	-46~425

Casting

Material Table-Metal

PARTS	ASME	DIN/EN	Cr	Ni	Mo	Ti	Temp.Range
Forging	A 182 F304	174,401.4301	18~20	8~11	-	-	≤800/540
	A 182 F321	X10CrNiTi18-9,1.4541	17~21	9~12	-	0.7	≤800/540
	A 182 F316	174,401.4401	16~18	10~14	2~3	-	800/540
	A 182 F316L	174,401.4404	16~18	10~15	2~3	-	≤450
	A 182 F304L	174,401.4306	18~20	8~13	-	-	≤425
	A 182F310		24~26	19~22			-29~800
	Duplex2205	X2CrNiMoN22-5-3,1.4462	21~24	4.5~6.5	2.5~3.5	-	≤450
	Duplex2304	X2CrNiN23-4,1.4362	21.5~24.5	3~5.5	0.05~0.6	-	≤425
	Duplex2507	X2CrNiMoN25-7-4,1.4410	24~26	6~8	3~5	-	-40~315
	A 182 F51	X2 CrNiMoN 22-5-3,1.4462	21~23	4.5~6.5	2.5~3.5	-	-40~315
	A 182 F1	1.5Mo3,1.5415	-	-	0.44~0.65	-	≤470
	A 182 F2	1.7335,1.7337	0.5~0.81	-	0.44~0.65	-	≤540
	A 182 F11	13CrMo4-4,1.7335	1~1.5	-	0.44~0.65	-	≤545
	A 182F22	10CrMo9-10,1.7380		0.87~1.13		-	≤550
	A 182 F12	13CrMo4-5,1.7335	0.8~1.25	-	0.44~0.65	-	≤545
	A 182 F9	X12CrMo 9-1,1.7386	8~10	-	0.9~1.1	-	≤673
	A 182 F91	1.4903,1.7332	8~9.5	0.4	0.85~1.05	-	≤673
	A 182 F5		4~6.5	0.5	0.44~0.65	-	≤550
	A 182F6a	X10Cr13	11.5~13.5	0.5	-	-	-101~480
	A 182 F44	X1CRNiMoCuN20-18-7,1.4547	19.5~20.5	17.5~18.5	6~6.5	-	≤540
Rod	Aisi 410	X12CrN13,1.4006	11.5~13.5	0.6	-	-	-101~480
	Aisi 416	X20Cr13	12~14	-	-	-	-38~350
	Aisi 420	X20Cr13	12~14	-	-	-	-101~480
	Aisi 430	X6Cr17	16~18	-	-	-	-101~480
	Aisi431	Z15CN16-02,1.4057	16~18	1.5~2.5	-	0.2	-38~425
	A276 XM-19	GX4CrNiMnN22-12-5,1.3964	20.5~23.5	11.5~13.5~13.5	1.5~3		≤550
	A 193 B7		0.75~1.2		0.15~0.25		-45.6~510
	A 193 B7M		0.75~1.2		0.15~0.25	-	-20~510
	A 193 B16		0.8~1.15	-	0.5~0.65	-	-10~600
	A320 L7		0.8~1	-	0.15~0.25	-	-101~550
	A320 B8		18~20	8~10.5	-	-	254~700
	A320 B8A		18~20	8~10.5	-	-	254~700
	A320 B8M		16~18	10~14	-	-	254~816
A320 B8T		17~19	9~12	2~3	-	196~700	
Fasteners	A 1942H		-	-	-	-	-38~450
	A 1946		11.5~13.5	-		-	-101~480
	A 1948,8A		8~10.5	18~20	-		-254~800
	A 1948M,8MA		16~18	10~14	2~3	-	-254~816
	A 1948T,8TA		17~19	9~12	-		0.3~0.6 -196~700
	D507Mo		10~16	6	2.5	-	≤450
	Alloy 20		19~21	32~38	2~3	-	≤427
	Alloy 904L		19~23	23~28	4~5	-	≤700
Surfacing welding	Uranus B-6		20.5	25.5	4.5	-	≤700
	Lewmet 25		29	-	4.5	-	≤700
	Stellite Alloy 6		27~32	3	1	-	≤700
	Inconel Alloy 625		20~23	58	8~10	0.4	≤700
	Hastelloy AlloyC-276		15.5	-	16	-	≤700

Seal parts

Parts	Characteristic	Low/High Temperature		Recommended
NR	High elasticity	-20	85	-5~70
NBR	Oil resistivity	-30	100	-15~90
EPDM	Aging resistance, ozone resistance, corrosion resistance	-40	125	-25~110
HT EPDM	Same as above, added heat resistance	-40	150	-25~135
SBR (wear-resistant)	Excellent traction performance and wear resistance	-30	100	-15~80
CR (neoprene)	Oil, heat, flame, sunlight, ozone, acid and alkali resistance	-30	125	-15~100
Hypalon	Oxidation resistance, resistance to winding and cracking	-40	120	-25~110
FPM (viton)	Chemical and most oils resistance, (except ketones & esters)	-20	200	-5~150
MVQ (silicon)	High and low temperature resistance, oil, corrosion resistance	-55	200	-30~180
PU	Chemical, oil, wear, low temperature, aging resistance	-20	120	-5~90
FEP (F46)	Chemical resistance, radiation resistance	-20	150	-5~120
PTFE	Heat, cold, acid, alkali, organic solvents resistant	-60	180	-45~150
RPTFE	Corrosion resistance, low friction coefficient	-60	180	-45~150
PFA	Excellent chemical corrosion resistance, low friction coefficient	-196	200	-60~180
PPL	High temperature and chemical corrosion resistance	-60	230	-45~200
UPVC	Corrosion and pressure resistance, hygiene	-30	100	-15~80
CPVC	Corrosion and pressure resistance, hygiene	-30	110	-15~95
PVDF	Anti aging and chemical resistance	-30	100	-15~70
PEEK	High temperature and chemical resistance	-60	300	-45~260
Flexible graphite	Cold and hot resistant, corrosion resistant, self-lubricating	-200	600	-60~550
Ceramic fiber	Fire, high temperature resistance, low thermal conductivity	-200	1050	-60~950
Metal to metal	High temperature, high pressure, wear, corrosion resistance	Refer to the material		

Unit: Degree

Inspection Standards and Requirements

Inspection Standards and Requirements							
		ISO5208:2008 / GB/T13927			API598-2004		
Shell strength	Medium temperature	5~40			5~40		
	Medium	Water, kerosene, air, suitable gas			Water, kerosene, air, suitable gas		
	Test pressure	Nominal pressure (PN)×1.5			Nominal pressure×1.5		
	Minimum duration of the test	DN	Seconds		NPS	Check valve	Others
		≤50	15		≤2"	60	15
		65~200	60		2½"~6"	60	60
≥250		180		8"~12"	60	120	
Assessment	No visible leakage allowed			No visible leakage allowed			
Back seal	Test pressure	DN	PN	Pressure	NPS	Class	Pressure
		≤80	All	0.6Mpa	All	≤300	0.4~0.7Mpa
		100~200	≤5.0	0.6Mpa			
		100~200	>5.0	PN × 1.1		>300	Class x 1.1
	≥250	All	PN × 1.1				
Assessment	No visible leakage allowed			No visible leakage allowed			
High pressure sealing test	Test pressure	DN	PN	Pressure	Class	Ductile iron	Steel
		≤80	All	PN × 1.1 (liquid)	150	1.7 Mpa	Class x 1.1
		100~200	≤5.0	0.5~0.7Mpa (air)			
		100~200	>5.0	PN × 1.1 (liquid)	300	4.4 Mpa	
		≥250	All	0.5~0.7Mpa (air)			
		100~200	>5.0	PN × 1.1 (liquid)	300	4.4 Mpa	
	≥250	All	PN × 1.1 (liquid)				
	Minimum duration of the test	DN	Metal seal	Resilient seal	NPS	Check valve	Others
		≤50	15	15	≤2"	60	15
		65~200	30	15	2½"~6"	60	60
		250~450	60	30	8"~12"	60	120
		≥500	120	60	≥14"	120	120
	Assessment	Class (level)	Liquid leakage	Air leakage	NPS	Liquid & Air	Liquid & Air
		A	No visible leakage allowed (mm ³ /s)		≤2"	Liquid:3cm ³ /in. min Air:0.042m ³ /in.h	0 drop(bubble)/min
		B	DN x 0.01	DN x 0.3	2½"~6"		12 & 24
		C	DN x 0.03	DN x 3	8"~12"		20 & 40
D	DN x 0.1	DN x 30	≥14"			2 & 4 / in ·min	
Low pressure sealing test	Medium	Air, suitable gas			Air, suitable gas		
	Test pressure	0.5~0.7 Mpa			0.4~0.7 Mpa		
		DN	Metal seal	Resilient seal	NPS	Check valve	Others
		≤50	15	15	≤2"	60	15
	Minimum duration of the test	65~200	30	15	2½"~6"	60	60
		250~450	60	30	8"~12"	60	120
		≥500	120	60	≥14"	120	120
	Assessment	Class (level)	Air leakage		NPS	Air leakage	
		A	No visible leakage allowed (mm ³ /s)		≤2"		0 bubble /min
		B	DN x 0.3		2½"~6"	0.042 m ³ /in ·h	24
C		DN x 3		8"~12"		40	
D	DN x 30		≥14"			4 / in ·min	

Flange connection dimensions

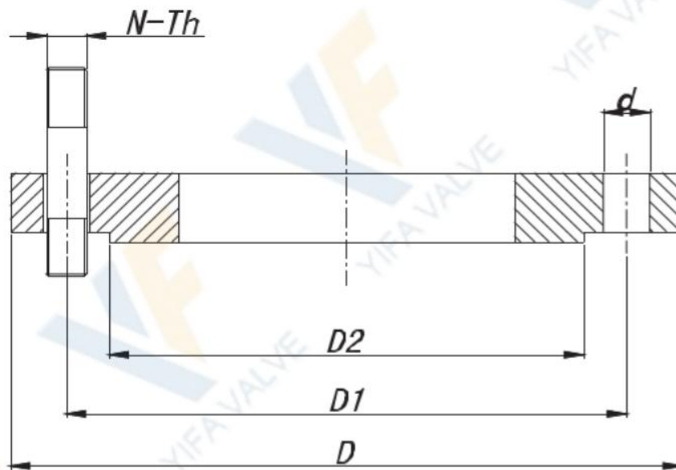

- D- Flange outer diameter
- D1- Bolt circle diameter
- D2- Diameter of sealing surface
- N-Th Bolt size
- d- Bolt hole diameter

PN10 (DIN2632)

DN	D	D1	D2	N-Th	d
50	165	125	102	4-M16	Φ18
65	185	145	122	4-M16	Φ18
80	200	160	138	8-M16	Φ18
100	220	180	158	8-M16	Φ18
125	250	210	188	8-M16	Φ18
150	285	240	212	8-M20	Φ23
200	340	295	268	12-M20	Φ23
250	405	355	320	12-M24	Φ27
300	460	410	378	12-M24	Φ27
350	520	470	438	16-M24	Φ27
400	580	525	490	16-M27	Φ30
450	640	585	550	20-M27	Φ30
500	715	650	610	20-M30	Φ33
600	840	770	725	20-M33	Φ36
700	910	840	795	24-M33	Φ36
800	1025	950	900	24-M36	Φ39
900	1125	1050	1000	28-M36	Φ39
1000	1255	1170	1115	28-M39	Φ42
1200	1485	1390	1330	32-M45	Φ48
1400	1685	1590	1530	36-M45	Φ48
1600	1930	1820	1750	40-M52	Φ56
1800	2130	2020	1950	44-M52	Φ56
2000	2345	2230	2150	48-M56	Φ62

PN16 (DIN2632)

DN	D	D1	D2	N-Th	d
50	165	125	102	4-M16	Φ18
65	185	145	122	4-M16	Φ18
80	200	160	138	8-M16	Φ18
100	220	180	158	8-M16	Φ18
125	250	210	188	8-M16	Φ18
150	285	240	212	8-M20	Φ23
200	340	295	268	12-M20	Φ23
250	405	355	320	12-M24	Φ27
300	460	410	378	12-M24	Φ27
350	520	470	438	16-M24	Φ27
400	580	525	490	16-M27	Φ30
450	640	585	550	20-M27	Φ30
500	715	650	610	20-M30	Φ33
600	840	770	725	20-M33	Φ36
700	910	840	795	24-M33	Φ36
800	1025	950	900	24-M36	Φ39
900	1125	1050	1000	28-M36	Φ39
1000	1255	1170	1115	28-M39	Φ42
1200	1485	1390	1330	32-M45	Φ48
1400	1685	1590	1530	36-M45	Φ48
1600	1930	1820	1750	40-M52	Φ56
1800	2130	2020	1950	44-M52	Φ56
2000	2345	2230	2150	48-M56	Φ62

Flange connection dimensions

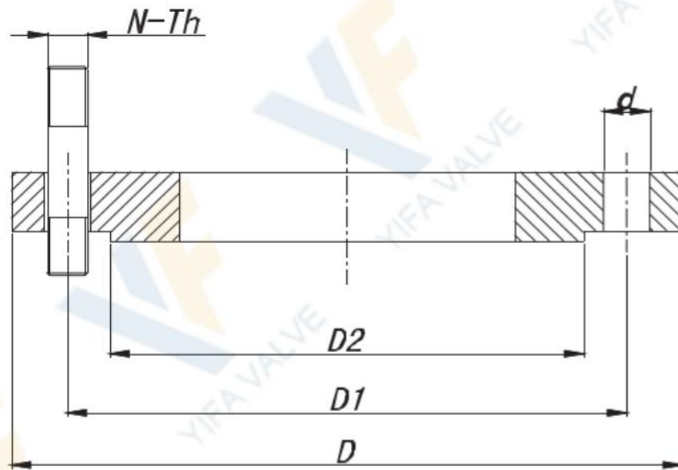

- D- Flange outer diameter
- D1- Bolt circle diameter
- D2- Diameter of sealing surface
- N-Th Bolt size
- d- Bolt hole diameter

PN10 (GB/T9113.1)

DN	D	D1	D2	N-Th	d
50	165	125	99	4-M16	Φ18
65	185	145	118	4-M16	Φ18
80	200	160	132	8-M16	Φ18
100	220	180	156	8-M16	Φ18
125	250	210	184	8-M16	Φ18
150	285	240	211	8-M20	Φ23
200	340	295	266	8-M20	Φ23
250	395	350	319	12-M20	Φ23
300	445	400	370	12-M20	Φ23
350	505	460	429	16-M20	Φ23
400	565	515	480	16-M24	Φ27
450	615	565	530	20-M24	Φ27
500	670	620	582	20-M24	Φ27
600	780	725	682	20-M27	Φ30
700	895	840	794	24-M27	Φ30
800	1015	950	901	24-M30	Φ33
900	1115	1050	1001	28-M30	Φ33
1000	1230	1160	1112	28-M33	Φ36
1200	1455	1380	1328	32-M36	Φ39

PN16 (GB/T9113.1)

DN	D	D1	D2	N-Th	d
50	165	125	99	4-M16	Φ18
65	185	145	118	4-M16	Φ18
80	200	160	132	8-M16	Φ18
100	220	180	156	8-M16	Φ18
125	250	210	184	8-M16	Φ18
150	285	240	211	8-M20	Φ23
200	340	295	266	12-M20	Φ23
250	405	355	319	12-M24	Φ27
300	460	410	370	12-M24	Φ27
350	520	470	429	16-M24	Φ27
400	580	525	480	16-M27	Φ30
450	640	585	548	20-M27	Φ30
500	715	650	609	20-M30	Φ33
600	840	770	720	20-M33	Φ36
700	910	840	794	24-M33	Φ36
800	1025	950	901	24-M36	Φ39
900	1125	1050	1001	28-M36	Φ39
1000	1255	1170	1112	28-M39	Φ42
1200	1485	1390	1328	32-M45	Φ48

Flange and connection details

GB/T9113.1 PN10

DN	D1	n°	M	T	●	⊕	+
50	125	4	M-16	10	2--0		-2
65	145	4	M-16	10	2--0		-2
80	160	8	M-16	12	2--4		-2
100	180	8	M-16	12	2--4		-2
125	210	8	M-16	14	2--4		-2
150	240	8	M-20	14	2--4		-2
200	295	8	M-20	14	2--4		-2
250	350	12	M-20	18	4--6		-2
300	400	12	M-20	21	4--6		-2
350	460	16	M-20	21	6--8		-2
400	515	16	M-24	25	6--8		-2
450	565	20	M-24	25	8--10		-2
500	620	20	M-24	26	8--10		-2
600	725	20	M-27	26	8--10		-2
700	840	24	M-27	22	10--12		-2
800	950	24	M-30	22	10--12		-2
900	1050	28	M-30	22	12--12		-4
1000	1160	28	M-33	22	12--12		-4
1200	1380	32	M-36	33	14--14		-4

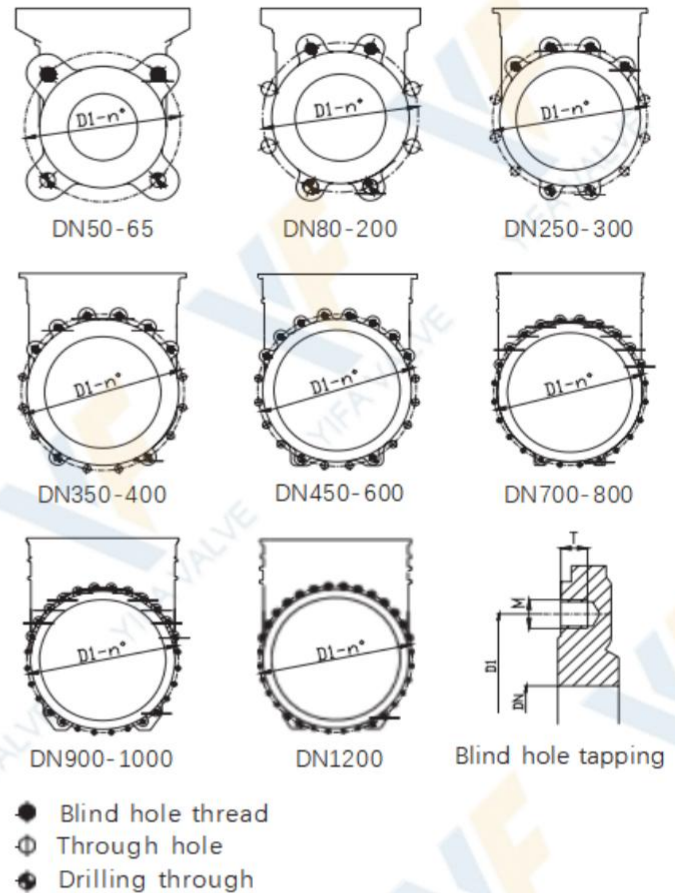

GB/T9113.1 PN16

DN	D1	n°	M	T	●	⊕	+
50	125	4	M-16	10	2--0		-2
65	145	4	M-16	10	2--0		-2
80	160	8	M-16	12	2--4		-2
100	180	8	M-16	12	2--4		-2
125	210	8	M-16	14	2--4		-2
150	240	8	M-20	14	2--4		-2
200	295	12	M-20	14	2--4		-2
250	355	12	M-24	18	4--6		-2
300	410	12	M-24	21	4--6		-2
350	470	16	M-24	21	6--8		-2
400	525	16	M-27	25	6--8		-2
450	585	20	M-27	25	8--10		-2
500	640	20	M-30	26	8--10		-2
600	725	20	M-33	26	8--10		-2
700	840	24	M-33	22	10--12		-2
800	950	24	M-36	22	10--12		-2
900	1050	28	M-36	22	12--12		-4
1000	1170	28	M-39	22	12--12		-4
1200	1390	32	M-45	33	14--14		-4

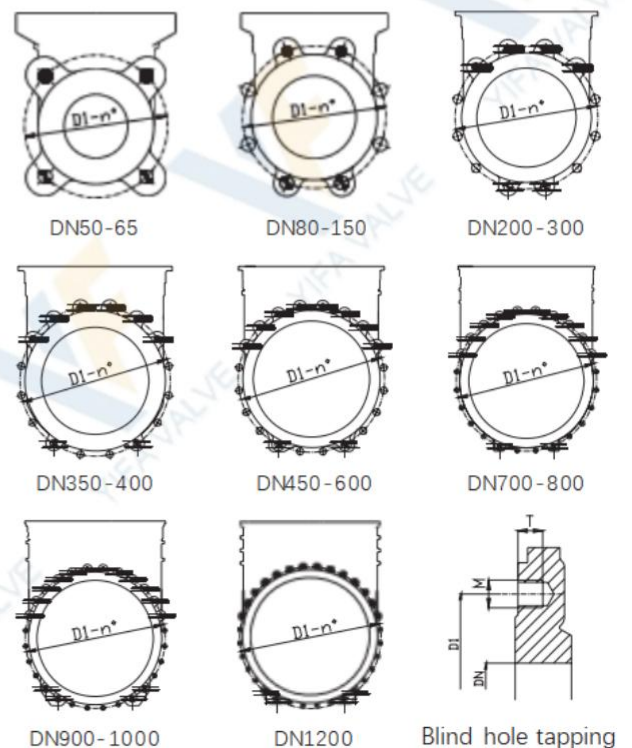

Flange connection dimensions

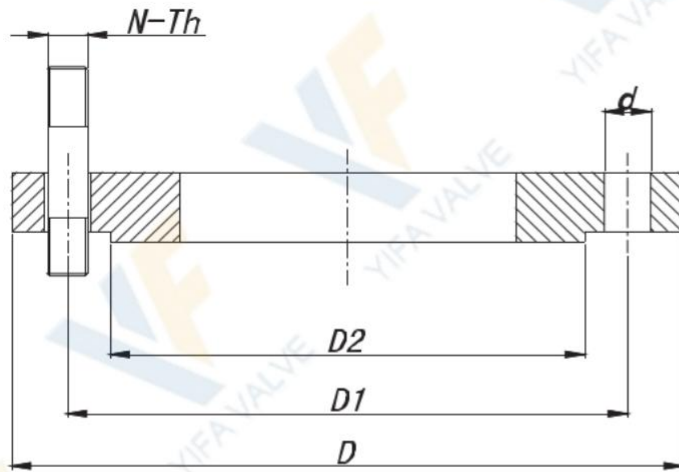

- D- Flange outer diameter
- D1- Bolt circle diameter
- D2- Diameter of sealing surface
- N-Th Bolt size
- d- Bolt hole diameter

10K (JIS B2239-2004)

150Lb (ANSI B16.5 & ASME B16.47)

DN	D	D1	D2	N-Th	d
50	155	120	96	4-M16	Φ19
65	175	140	116	4-M16	Φ19
80	185	150	126	8-M16	Φ19
100	210	175	151	8-M16	Φ19
125	250	210	182	8-M20	Φ23
150	280	240	212	8-M20	Φ23
200	330	290	262	12-M20	Φ23
250	400	355	324	12-M22	Φ25
300	445	400	368	16-M22	Φ25
350	490	445	413	16-M22	Φ25
400	560	510	475	16-M24	Φ27
450	620	565	530	20-M24	Φ27
500	675	620	585	20-M24	Φ27
550	745	680	640	20-M30	Φ33
600	795	730	690	24-M30	Φ33
650	845	780	740	24-M30	Φ33
700	905	840	800	24-M30	Φ33
750	970	900	855	24-M30	Φ33
800	1020	950	905	28-M30	Φ33
850	1070	1000	955	28-M30	Φ33
900	1120	1050	1005	28-M30	Φ33
1000	1235	1160	1110	28-M36	Φ39
1100	1345	1270	1220	28-M36	Φ39
1200	1465	1380	1325	32-M36	Φ39
1350	1630	1540	1480	36-M42	Φ45
1500	1795	1700	1635	40-M42	Φ45

DN	D	D1	D2	N-Th	d
2D	153	120.5	92	4-5/8DUNC	Φ19
2.5D	178	139.5	105	4-5/8DUNC	Φ19
3D	191	152.5	127	4-5/8DUNC	Φ19
4D	229	190.5	157	8-5/8DUNC	Φ19
5D	254	216	186	8-3/4DUNC	Φ22
6D	280	241.5	216	8-3/4DUNC	Φ22
8D	343	298.5	270	8-3/4DUNC	Φ22
10D	407	362	324	12-7/8DUNC	Φ25
12D	483	432	381	12-7/8DUNC	Φ25
14D	534	476	413	12-1DUNC	Φ29
16D	597	539.5	470	16-1DUNC	Φ29
18D	635	578	534	16-1 1/8DUNC	Φ32
20D	699	635	584	20-1 1/8DUNC	Φ32
24D	813	749.5	692	20-1 1/4DUNC	Φ35
26D	870	806.5	749	24-1 1/4DUNC	Φ35
28D	925	863.5	800	28-1 1/4DUNC	Φ35
30D	985	914.5	857	28-1 1/4DUNC	Φ35
32D	1060	978	914	28-1 1/2DUNC	Φ41
36D	1170	1086	1022	32-1 1/2DUNC	Φ41
40D	1290	1200	1124	36-1 1/2DUNC	Φ41
42D	1345	1257	1194	36-1 1/2DUNC	Φ41
44D	1405	1314	1245	40-1 1/2DUNC	Φ41
48D	1510	1422	1359	44-1 1/2DUNC	Φ41
52D	1625	1537	1461	44-1 3/4DUNC	Φ47
56D	1745	1651	1575	48-1 3/4DUNC	Φ47
60D	1855	1759	1676	52-1 3/4DUNC	Φ47

Flange and connection details

JIS B2239-2004 10K

DN	D1	n°	M	T	●	⊕	+
50	120	4	M-16	10	2--0		-2
65	140	4	M-16	10	2--0		-2
80	150	8	M-16	12	2--4		-2
100	175	8	M-16	12	2--4		-2
125	210	8	M-20	14	2--4		-2
150	240	8	M-20	14	2--4		-2
200	290	12	M-20	14	2--4		-2
250	355	12	M-22	18	4--6		-2
300	400	16	M-22	21	4--6		-2
350	445	16	M-22	21	6--8		-2
400	510	16	M-24	25	6--8		-2
450	565	20	M-24	25	8--10		-2
500	620	20	M-24	26	8--10		-2
600	730	24	M-30	26	8--10		-2
700	840	24	M-30	22	10--12		-2
800	950	28	M-30	22	10--12		-2
900	1050	28	M-30	22	12--12		-4
1000	1160	28	M-30	22	12--12		-4
1200	1380	32	M-36	33	14--14		-4

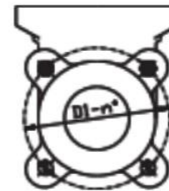

DN50-65



DN80-150

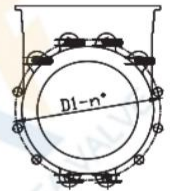

DN200-250

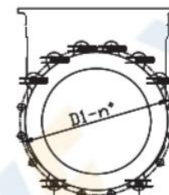

DN300-400



DN450-500

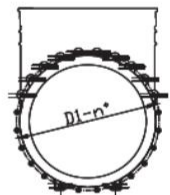

DN600-700

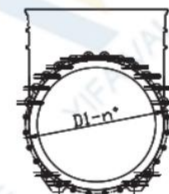

DN800-1000

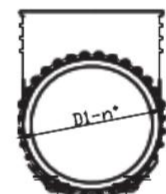

DN1200

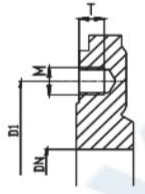

Blind hole tapping

- Blind hole thread
- ⊕ Through hole
- ⦿ Drilling through

ANSI B16.5 & ASME B16.47 150Lb

DN	D1	n°	M	T	●	⊕	+
2"	120.5	4	5/8" UNC	10	2--0		-2
2 1/2"	139.5	4	5/8" UNC	10	2--0		-2
3"	152.5	4	5/8" UNC	12	2--4		-2
4"	190.5	8	5/8" UNC	12	2--4		-2
5"	216	8	3/4" UNC	14	2--4		-2
6"	241.5	8	3/4" UNC	14	2--4		-2
8"	298.5	8	3/4" UNC	14	2--4		-2
10"	362	12	7/8" UNC	18	4--6		-2
12"	432	12	7/8" UNC	21	4--6		-2
14"	476	12	1" UNC	21	6--8		-2
16"	540	16	1" UNC	25	6--8		-2
18"	578	16	1 1/8" UNC	25	8--10		-2
20"	635	20	1 1/8" UNC	26	8--10		-2
24"	749.5	20	1 1/4" UNC	26	8--10		-2
28"	863.5	28	1 1/4" UNC	26	10--12		-2
30"	914	28	1 1/4" UNC	22	10--12		-2
32"	978	28	1 1/2" UNC	22	12--12		-4
36"	1085.8	32	1 1/2" UNC	22	12--12		-4
40"	1200.2	36	1 1/2" UNC	30	14--14		-4

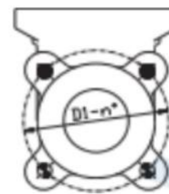

2"-3"

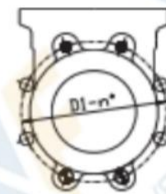

4"-8"

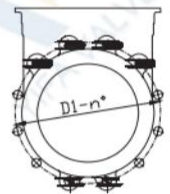

10"-14"

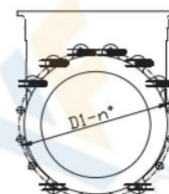

16"-18"

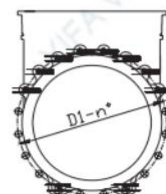

20"-24"

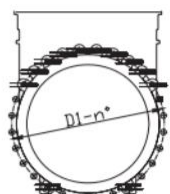

28"-32"

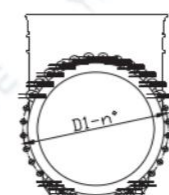

36"

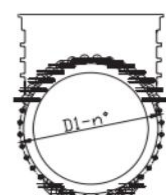

40"

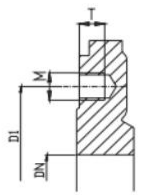

Blind hole tapping



ADDRESS

No.2 Road, Jinnan District
Industrial Zone, Xiaozhan
Town, Jinnan District, Tianjin,
China



PHONE

0086 0379 69926196



EMAIL

valve@yifavalves.com